

## 10 Gb/s 1310nm SFP+ 10 km Transceiver

---

### SFP+ Series



- Up to 11.32 Gbps Data Links
- Up to 10 km transmission on SMF
- DFB Laser and PIN/TIA receiver
- Hot-pluggable SFP+ footprint
- Support Commercial and Industrial Temperature
- Compliant with SFP-8431, SFP-8432, SFP-8472, IEEE802.3ae

The transceiver consists of five sections: the LD driver, the limiting amplifier, the digital diagnostic monitor, the 1310nm FP laser and the PIN photo-detector. The module data link up to 10 km using 9/125  $\mu$ m single-mode fiber.

The optical output can be disabled by a TTL logic high-level input of Tx Disable, and the system also can disable the module via I2C. Tx Fault is provided to indicate that degradation of the laser. Loss Of signal (LOS) output is provided to indicate the loss of an input optical signal of receiver or the link status with partner.

The system can also get the LOS (or Link)/Disable/Fault information via I2C register access. The metal housing ensures low EMI interference standards, with connector retainer.

## Key Features

- Compliant with SFP+ MSA
- Support data rate up to 11.32Gb/s
- Hot-Pluggable SFP Footprint and Dual LC Connector
- Up to 10km reach for G.652 SMF
- 1310nm DFB laser and PINreceiver
- ESD protect
- Low EMI metals
- Temperature Range:  
Commercial: 0°C to +70°C  
Industrial: -40°C to +85°C
- Compliant with SFP-8431
- Compliant with SFP-8432
- Compliant with SFP-8472
- Compliant with IEEE802.3ae
- RoHS, FCC compliant

## Outline Diagram

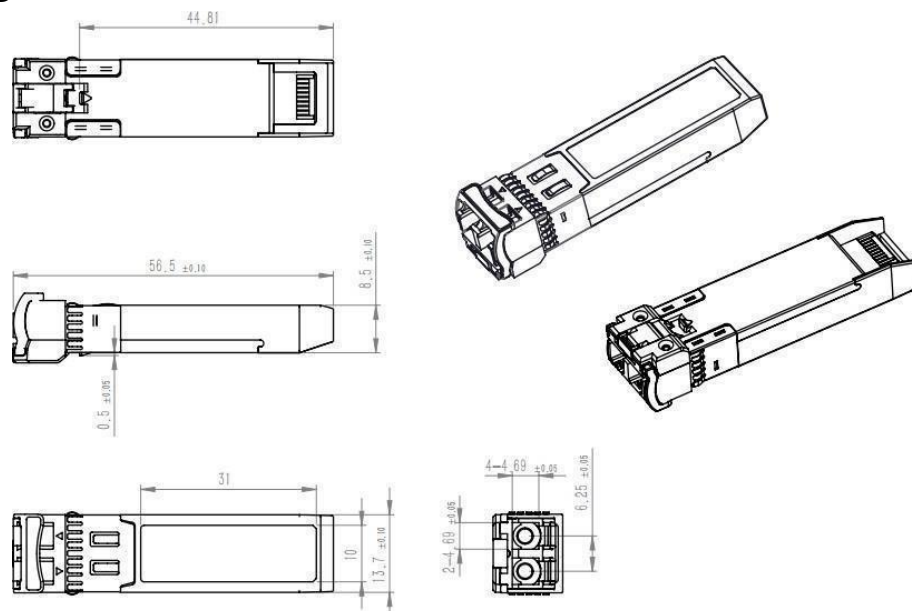

## Recommend Circuit Schematic

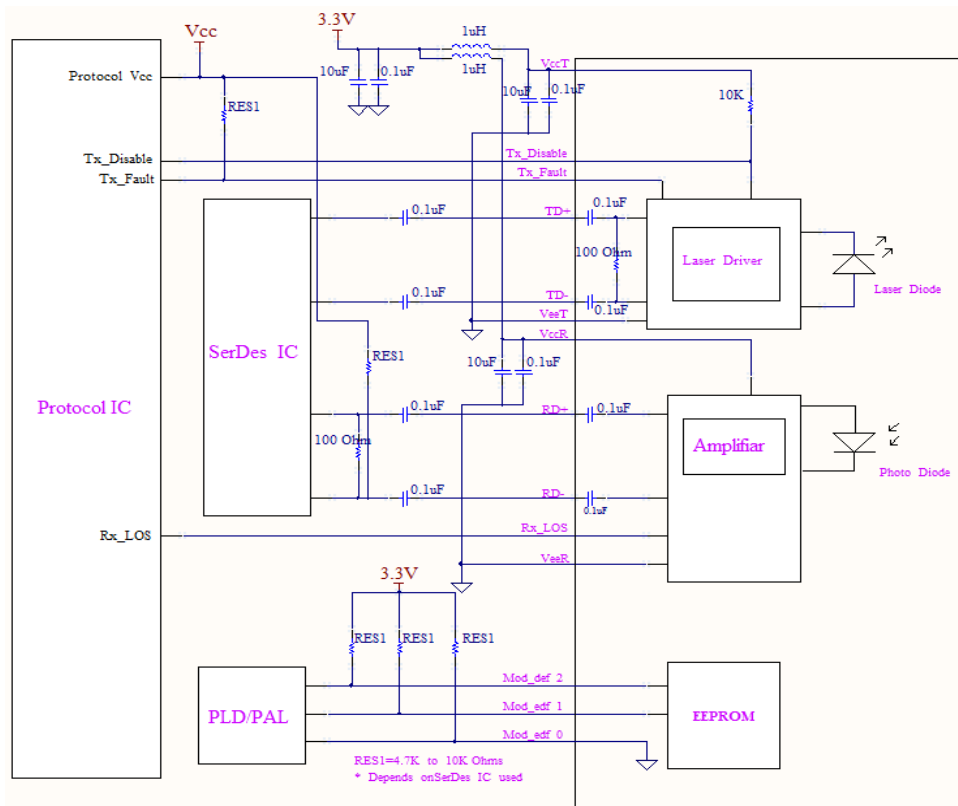

## Digital Diagnostic Functions

Parameter	Range	Unit	Accuracy	Calibration
Case Temperature	0 to +70	°C	±3°C	Internal / External
Industrial Temperature	-30 to +85	°C	±3°C	Internal / External
Voltage	3.0 to 3.6	V	±3%	Internal / External
Bias Current	10 to 100	mA	±10%	Internal / External
TX Power	-6 to +0	dBm	±3dB	Internal / External
RX Power	-15 to +0.5	dBm	±3dB	Internal / External

**Note:** The transceivers provide serial ID memory contents and diagnostic information about the present operating conditions by the 2-wire serial interface (SCL, SDA). The diagnostic information with internal calibration or external calibration all are implemented, including received power monitoring, transmitted power monitoring, bias current monitoring, supply voltage monitoring and temperature monitoring.

## Pin Assignment

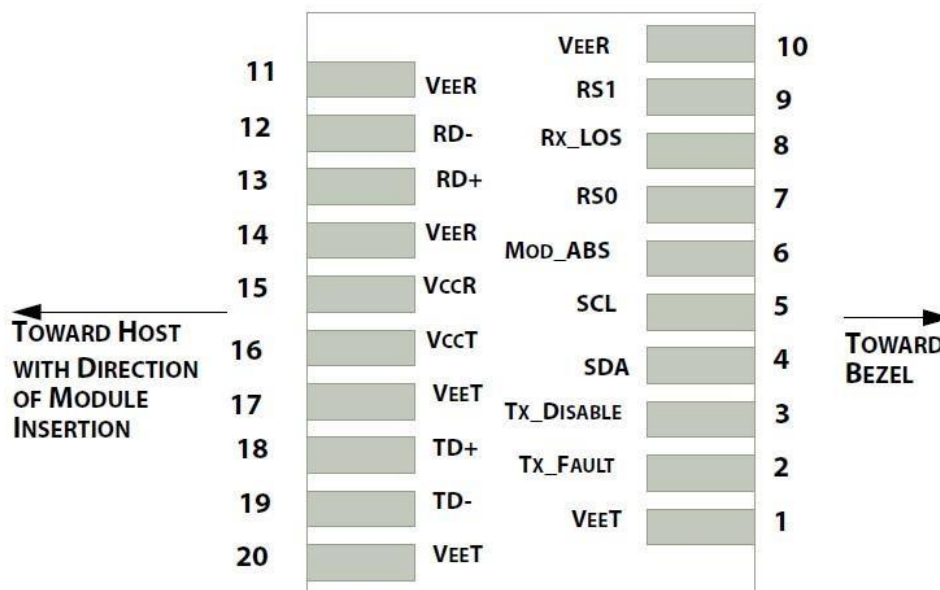

Pin	Name	Function	Notes
1	VeeT	Module transmitter ground	1
2	Tx Fault	Module transmitter fault	2
3	Tx Disable	Transmitter Disable; Turns off transmitter laser output	3
4	SDL	2 wire serial interface data input/output (SDA)	4
5	SCL	2 wire serial interface clock input (SCL)	4
6	MOD_ABS	Module Absent. Grounded within the module	4
7	RS0	Rate select0, optionally control SFP+ receiver. When high, input data rate >4.5Gb/ s; when low, input data rate <=4.5Gb/s	5
8	LOS	Receiver Loss of Signal Indication	6
9	RS1	Rate select0, optionally control SFP+ transmitter. When high, input data rate >4.5Gb/s; when low, input data rate <=4.5Gb/s	1
10	VeeR	Module receiver ground	1
11	VeeR	Module receiver ground	1
12	RD-	Receiver inverted data out put	
13	RD+	Receiver non-inverted data out put	
14	VeeR	Module receiver ground	1
15	VccR	Module receiver 3.3V supply	
16	VccT	Module transmitter 3.3V supply	
17	VeeT	Module transmitter ground	1
18	TD+	Transmitter inverted data out put	
19	TD-	Transmitter non-inverted data out put	
20	VeeT	Module transmitter ground	1

**Note:**

1. Circuit ground is internally isolated from chassis ground
2. Tx FAULT is an open collector/drain output, which should be pulled up with a 4.7 kΩ to 10 kΩ resistor on

the host board if intended for use. Pull up voltage should be between 2.0V to Vcc + 0.3V. A high output indicates a transmitter fault caused by either the TX bias current or the TX output power exceeding the preset alarm thresholds. A low output indicates normal operation. In the low state, the output is pulled to <0.8V.

3. Laser output disabled on Tx DIS >2.0V or open, enabled on Tx DIS <0.8V.
4. Should be pulled up with 4.7kΩ- 10kΩ host board to a voltage between 2.0V and 3.6V. MOD\_ABS pulls line low to indicate module is plugged in.
5. Internally pulled down per SFF-8431 Rev 4.1.
6. LOS is open collector output. It should be pulled up with 4.7kΩ – 10kΩ on host board to a voltage between 2.0V and 3.6V. Logic 0 indicates normal operation; logic 1 indicates loss of signal.

## SFP Module EEPROM Information and Management

The SFP modules implement the 2-wire serial communication protocol as defined in the SFP -8472.

The serial ID information of the SFP modules and Digital Diagnostic Monitor parameters can be accessed through the I2C interface at address A0h and A2h.

The memory is mapped in below figure.

Detailed ID information (A0h) is listed in Table 2. And the DDM specification at address A2h.

For more details of the memory map and byte definitions, please refer to the SFF-8472, “Digital Diagnostic Monitoring Interface for Optical Transceivers”. The DDM parameters have been internally calibrated.

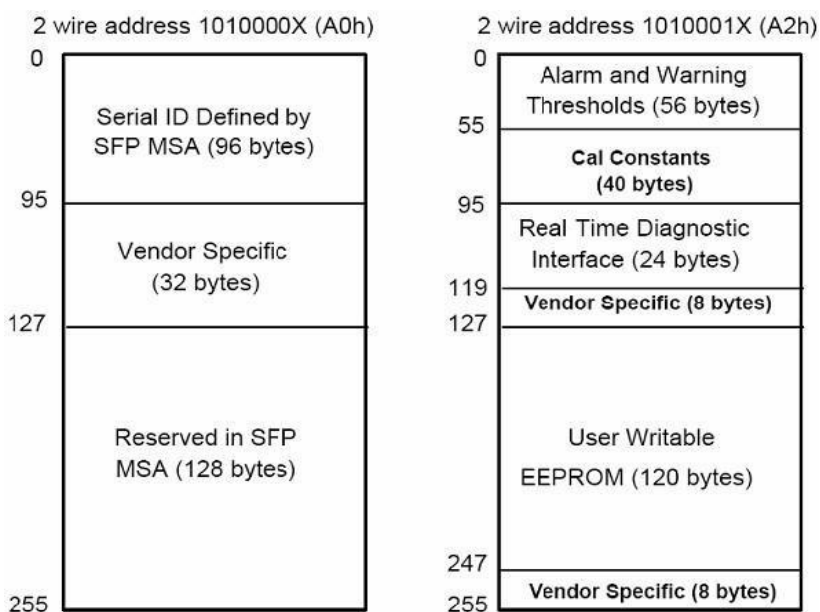

EEPROM Serial ID Memory Contents (A0h)

Data Address	Length (Byte)	Name of Length	Description and Contents
<b>Base ID Fields</b>			
0	1	Identifier	Type of Serial transceiver (03h=SFP)
1	1	Reserved	Extended identifier of type serial transceiver (04h)
2	1	Connector	Code of optical connector type (07=LC)
3-10	8	Transceiver	10G Base-ER
11	1	Encoding	64B/66B

Data Address	Length (Byte)	Name of Length	Description and Contents
12	1	BR, Nominal	Nominal baud rate, unit of 100Mbps
13-14	2	Reserved	(0000h)
15	1	Length(9um)	Link length supported for 9/125um fiber, units of 100m
16	1	Length(50um)	Link length supported for 50/125um fiber, units of 10m
17	1	Length(62.5um)	Link length supported for 62.5/125um fiber, units of 10m
18	1	Length(Copper)	Link length supported for copper, units of meters
19	1	Reserved	
20-35	16	Vendor Name	SFP vendor name: Ascent
36	1	Reserved	
37-39	3	Vendor OUI	SFP transceiver vendor OUI ID
40-55	16	Vendor PN	Part Number: "SFPP-ATLP-31-10" (ASCII)
56-59	4	Vendor rev	Revision level for part number
60-62	3	Reserved	
63	1	CCID	Least significant byte of sum of data in address 0-62
<b>Extended ID Fields</b>			
64-65	2	Option	Indicates which optical SFP signals are implemented (001Ah = LOS, TX_FAULT, TX_DISABLE all supported)
66	1	BR, max	Upper bit rate margin, units of %
67	1	BR, min	Lower bit rate margin, units of %
68-83	16	Vendor SN	Serial number (ASCII)
84-91	8	Date code	Manufacturing date code
92-94	3	Reserved	
95	1	CCEX	Check code for the extended ID Fields (addresses 64 to 94)
<b>Vendor Specific ID Fields</b>			
96-127	32	Readable	Specific date, read only
128-255	128	Reserved	Reserved for SFF-8079

### Alarm and Warning Thresholds (A2h)

Data Address	Length (Byte)	Name of Length	Description and Contents
<b>Base ID Fields</b>			
00-01	2	Temp High Alarm	MSB at low address
02-03	2	Temp Low Alarm	MSB at low address
04-05	2	Temp High	MSB at low address
06-07	2	Warning Temp Low	MSB at low address
08-09	2	Warning Voltage High Alarm	MSB at low address
10-11	2	Voltage Low Alarm	MSB at low address
12-13	2	Voltage High	MSB at low address
14-15	2	Warning Voltage Low	MSB at low address
16-17	2	Bias High Alarm	MSB at low address
18-19	2	Bias Low Alarm	MSB at low address
20-21	2	Bias High Warning	MSB at low address
22-23	2	Bias Low Warning	MSB at low address
24-25	2	TX Power High	MSB at low address

Data Address	Length (Byte)	Name of Length	Description and Contents
26-27	2	Alarm TX Power Low Alarm	MSB at low address
28-29	2	TX Power High	MSB at low address
30-31	2	Warning TX Power Low	MSB at low address
32-33	2	Warning RX Power High	MSB at low address
34-35	2	Alarm RX Power Low Alarm	MSB at low address
36-37	2	RX Power High Warning	MSB at low address
38-39	2	RX Power Low	MSB at low address
40-41	2	Warning Optional Laser	MSB at low address
42-43	2	Temp High Alarm Optional Laser Temp Low Alarm	MSB at low address
44-45	2	Optional Laser Temp High Warning	MSB at low address
46-47	2	Optional Laser Temp Low Warning	MSB at low address
48-49	2	Optional TEC	MSB at low address
50-51	2	Current High Alarm Optional TEC	MSB at low address
52-53	2	Current Low Alarm Optional TEC Current High Warning	MSB at low address
54-55	3	Optional TECCurrent Low Warning	MSB at low address
<b>Calibration Constants for External Calibration Option</b>			
56-91	36	Calibration Constants for External Calibration Option	Refer to the SFP 8472 Rev12.4
92-94	3	Reserved	
95	1	Checksum	Byte 95 contains the low order 8 bits of the sum of bytes 0-94
<b>Real Time Diagnostic and Control Registers</b>			
96-110	15	A/D Values and Status Bits	Refer to the SFP 8472 Rev12.4
111	1	Reserved	Reserved (was assigned to SFF-8079).
<b>Alarm and Warning Flag Bits</b>			
112-117	6	Optional Alarm and Warning Flag	Refer to the SFP 8472 Rev12.4
<b>Extended Module Control/Status Bytes</b>			
		Extended Module	
118-119	2	Control/Status Bytes	Refer to the SFP 8472 Rev12.4

### Optional Page Select Byte

120-126	7	Vendor Specific	Vendor specific memory addresses
127	1	Optional Page Select	Defines the page number for subsequent reads and writes to locations A2h

### User Accessible EEPROM Locations

128-247	120	User EEPROM	User writable EEPROM
---------	-----	-------------	----------------------

### Vendor Specific Control Function Locations

248-255	8	Vendor Specific	Vendor specific control function
---------	---	-----------------	----------------------------------

## Specifications

### Absolute Maximum Ratings

Parameter	Symbol	Min.	Typ.	Max.	Unit	Note
Storage Temperature	T <sub>s</sub>	-40		85	°C	
Maximum Supply Voltage	V <sub>cc</sub>	-0.5		3.6	V	
Operating Relative Humidity	RH			95	%	

### Recommended Operating Conditions

Parameter	Symbol	Min.	Typ.	Max.	Unit	Note
Operating Case Temperature	T <sub>OP</sub>			70	°C	Commercial
		-40	-	85		Industrial
Power Supply Voltage	V <sub>cc</sub>	3.1	3.3	3.5	V	
Data Rate	BR	1.25	10.3125		Gbps	
Transmission Distance	TD			10	km	
Coupled Fiber	Single-mode fiber					9/125 μm G.652

### Electrical Characteristics (TOP = T<sub>c</sub>, V<sub>cc</sub> = 3.1 to 3.5 Volts)

Parameter	Symbol	Min.	Typ.	Max.	Unit	Note
Power Supply Voltage	V <sub>cc</sub>	3.1		3.5	V	
Power Supply Current (Commercial)	I <sub>cc</sub>			300	mA	
Power Supply Current (Industrial)	I <sub>cc</sub>			360	mA	
Power Consumption (Commercial)	P			1.0	W	
Power Consumption (Industrial)	P			1.2	W	
<b>Transmitter Section</b>						
CML Inputs(Differential)	V <sub>in, pp</sub>	180		700	mV	
Input Impedance(Differential)	Z <sub>DIS</sub>	2		V <sub>cc</sub>	V	
TX_DIS Disable		2		V <sub>cc</sub> +0.3	V	
TX_DIS Enable		0		0.8	V	
TX_FAULT Fault		2		V <sub>cc</sub> +0.3	V	
TX_FAULT Normal		0		0.5	V	
<b>Receiver Section</b>						
CML Outputs (Differential)	V <sub>out</sub>	350		700	mVpp	1
Output Impedance (Differential)	Z <sub>out</sub>	90	100	105	Ohm	
RX_LOS LOS		2		V <sub>cc</sub> +0.3	V	2
RX_LOS Normal		0		0.8	V	2
MOD_DEF ( 0:2 ) VoH		2.5			V	With Serial ID



## Ordering Information

Product Name	Product Description
SFPP-ATLP-31-10	SFP+ plug-in, 10 Gbps, 10 km, TX=1310/RX wide, on two single-mode fibers, LC/PC Blue
SFPP-ATLP-31-10A	SFP+plug-in, 10 Gbps, 10 km, TX=1310/RX wide, on two single-mode fibers, LC/PC Blue, Industrial Temp -40 to +85°C
JSPP-ATLP-31-10	SFP+ plug-in, 10 Gbps, 10 km, TX=1310/RX wide, on two single-mode fibers, LC/PC Blue, Compatible with Juniper
JSPP-ATLP-31-10A	SFP+plug-in, 10 Gbps, 10 km, TX=1310/RX wide, on two single-mode fibers, LC/PC Blue, Industrial Temp -40 to +85°C, Compatible with Juniper

## Contact Information



### Ascent Communication Technology Ltd

#### AUSTRALIA

140 William Street, Melbourne  
Victoria 3000, AUSTRALIA  
Phone: +61-3-8691 2902

#### Hong Kong SAR

Room 1210, 12th Floor, Wing Tuck Commercial Centre  
181 Wing Lok Street, Sheung Wan , Hong Kong SAR  
Phone: +852-2851 4722

#### CHINA

Unit 1933, 600 Luban Road  
200023, Shanghai, CHINA  
Phone: +86-21-60232616

#### USA

2710 Thomes Ave  
Cheyenne, WY 82001, USA  
Phone: +1 203 350 9822

#### EUROPE

Pfarrer-Bensheimer-Strasse 7a  
55129 Mainz, GERMANY  
Phone: +49 (0) 6136 926 3246

#### VIETNAM

11th Floor, Hoa Binh Office Tower  
106 Hoang Quoc Viet Street, Nghia Do Ward  
Cau Giay District, Hanoi 10649, VIETNAM  
Phone: +84-24-37955917

**WEB:** [www.ascentcomtec.com](http://www.ascentcomtec.com)

**EMAIL:** [sales@ascentcomtec.com](mailto:sales@ascentcomtec.com)

Specifications and product availability are subject to change without notice.

Copyright © 2026 Ascent Communication Technology Limited. All rights reserved.

Ver. ACT\_SFPP-ATLP-31-10\_Datasheet\_V1m\_Jan\_2021