

25 Gb/s CWDM Dual SFP28 10 km Transceiver

SFP+ Series



- **Operating data rate up to 25.78Gbps**
- **Up to 10 km transmission distance**
- **Rate Adaptation**
- **Hot-pluggable 20pin connector**
- **Compliant with SFF 8472**
- **Fully RoHS Compliant**

ASCENT's SFP28 25Gbps CWDM DML Transceiver is a high-performance optical module designed for 10km reach applications supporting data rates from 24.33Gb/s to 25.78Gb/s. Operating over CWDM wavelengths from C27 to C37 on single-mode fiber, it meets the needs of next-generation data center interconnects, 5G fronthaul, and high-speed enterprise networking environments.

This compact hot-pluggable SFP28 module is built to comply with industry standards including SFP28 MSA, SFF-8431, and SFF-8432, and is available in both commercial and extended temperature ranges to meet diverse environmental demands. With a low-power 3.3V DC power supply, it helps reduce overall power consumption in dense network infrastructures. The optical assembly features a C27 to C37 DML laser transmitter and a PIN photodiode receiver integrated with a TIA, ensuring low jitter and exceptional bit error rate performance.

Engineered for cost-effectiveness, energy efficiency, and long-term reliability, this transceiver is ideal for customers seeking to maximize performance while minimizing operational costs.

Key Features

- Operating data rate up to 25.78125Gbps
- Up to 10km transmission distance
- Compliant to 25GBASE-LR of the IEEE 802.3cc standard
- High sensitivity Pin photodiode and TIA
- Low EMI
- LC duplex connector
- Hot pluggable 20pin connector
- Low power consumption ≤ 1.5 W
- Single +3.3V $\pm 5\%$ power supply
- Compliant with SFF-8472
- Fully RoHS Compliant
- Case operating temperature
Commercial: 0°C to +70°C
External: -20°C to +85°C

Mechanical Dimensions

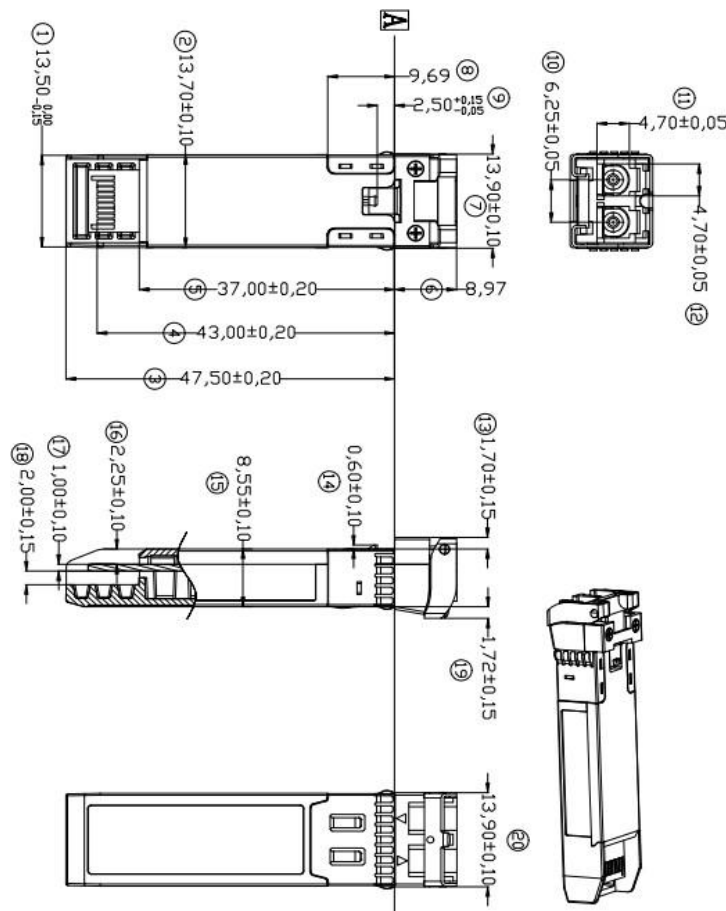

Recommended Interface Circuit

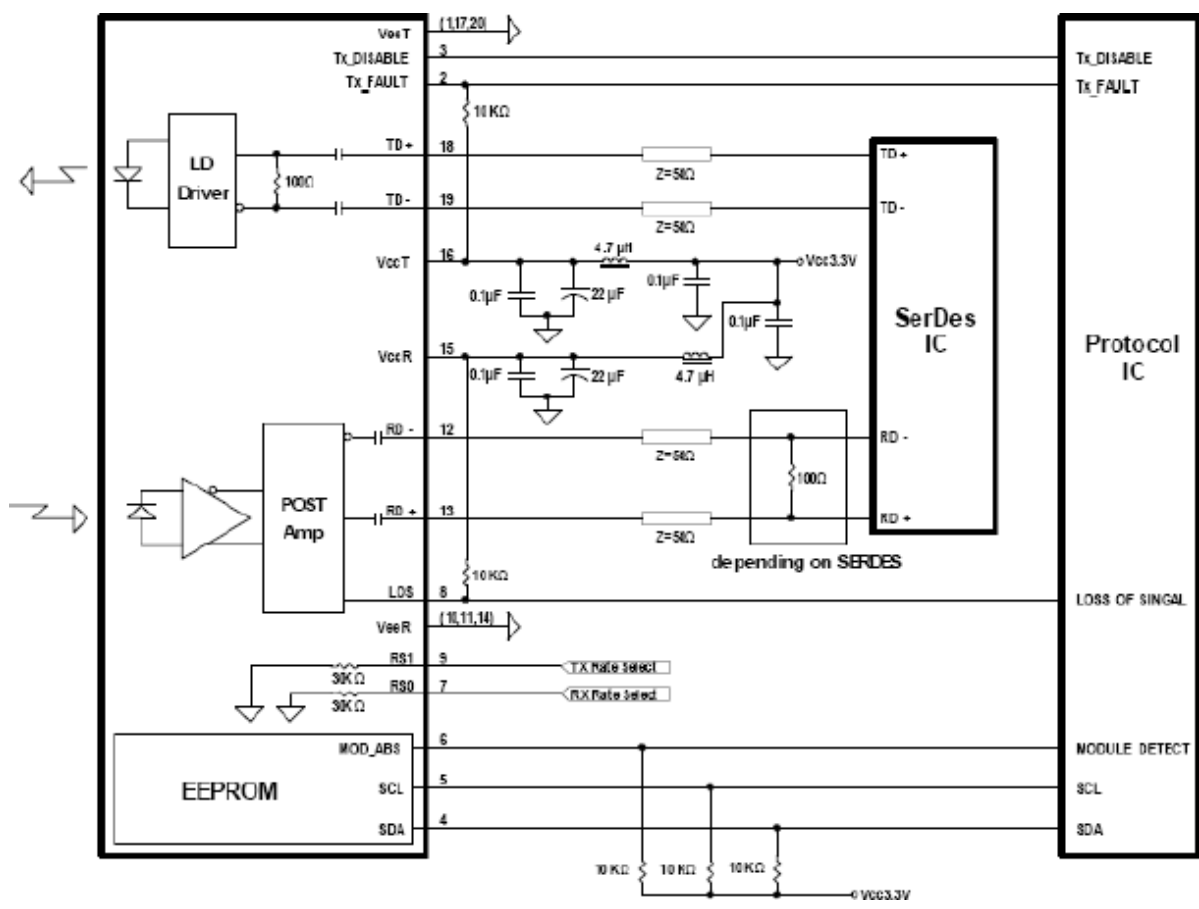

Pin Assignment

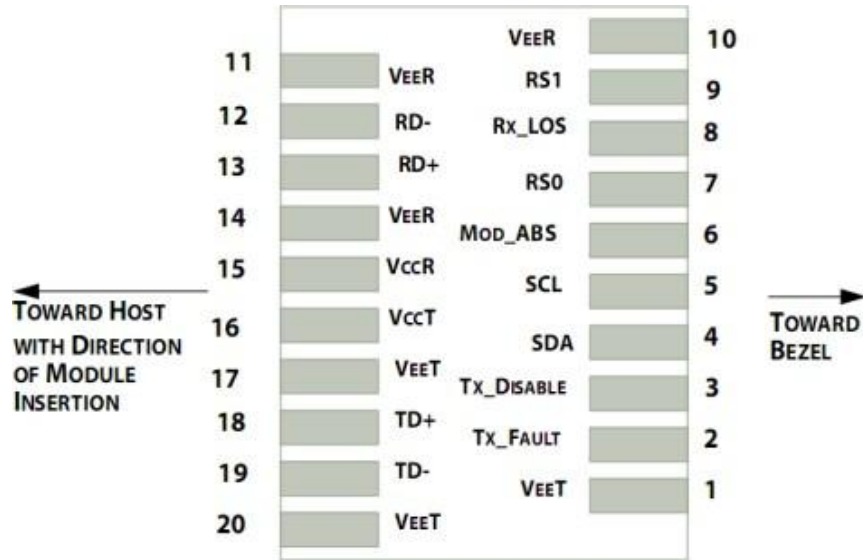

Pin	Symbol	Name	Description
1,17,20	VeeT	Transmitter Signal Ground	Connected to signal ground on the host board.
2	TX Fault	Transmitter Fault Out (OC)	Module transmitter fault output.
3	TX Disable	Transmitter Disable In (LVTTTL)	Module transmitter disable control.
4	SDA	Module Definition Identifiers	Serial ID with SFF 8472 Diagnostics
5	SCL	2-wire Serial Interface Clock Line	Module Definition pins should be pulled up to Host Vcc with 10 kΩ resistors.
6	MOD-ABS	Module Absent. Grounded within the module	
7	RS0	Receiver Rate Select (LVTTTL)	Rate select 0(Rx):Low=CDR Bypass ; High=CDR Select
8	RS1	Transmitter Rate Select (LVTTTL)	Rate select 1(Tx):Low=CDR Bypass ; High=CDR Select
9	LOS	Loss of Signal Out (OC)	Receiver loss of signal.
10,11,14	VeeR	Receiver Signal Ground	Connected to signal ground on the host board.
12	RD-	Receiver Negative DATA Out (CML)	Receiver inverted data output, internally AC coupled and terminated.
13	RD+	Receiver Positive DATA Out (CML)	Receiver non-inverted data output, internally AC coupled and terminated.
15	VccR	Receiver Power Supply	Receiver Power 3.3V Supply.
16	VccT	Transmitter Power Supply	Transmitter Power 3.3V Supply.
18	TD+	Transmitter Positive DATA In (CML)	Transmitter non-inverted data input, internally AC coupled and terminated.
19	TD-	Transmitter Negative DATA In (CML)	Transmitter inverted data Input, internally AC coupled and terminated.

Specifications

Absolute Maximum Ratings

Parameter	Symbol	Min.	Typ.	Max.	Unit	Note
Storage Temperature	Ts	-40		85	°C	
Relative Humidity	RH	0		95	%	

Recommended Operating Conditions

Parameter	Symbol	Min.	Typ.	Max.	Unit	Note
Case Operating Temperature	Tc	0		70	°C	
	Tc	-20		85	°C	
Power Supply Voltage	VCC	3.135	3.3	3.465	V	
Power Supply				350	mA	
Power Consumption				1.5	W	
Bit Rate	BR	24.33		25.78125	Gb/s	
Bit Error Ratio	BER			5*10 ⁻⁵		
Max Supported Link Length	TD			10	km	
	L			10	km	

Optical Characteristics(Ta and Vcc= 3.135V to 3.465V)

Parameter	Symbol	Min.	Typ.	Max.	Unit	Note
Transmitter						
Nominal Wavelength	λ	1271,1291,1311,1331,1351,1371			nm	
Wavelength Drift	$\Delta\lambda$	-6.5		+6.5	nm	
Output Power	Po	0		6	dBm	
Average Launch Power	Pav	0		6	dBm	
Spectral Width (-20dB)	$\Delta\lambda$			1	nm	
Extinction Ratio	ER	3.5			dB	
Side Mode Suppression Ratio	SMSR	30			dB	
Average Launch Power of OFF Transmitter	POFF			-30	dBm	
Relative Intensity Noise	RIN			-128	dB/Hz	
Receiver						
Center Wavelength	λ_C	1271,1291,1311,1331,1351,1371			nm	
Receiver Sensitivity(OMA)	RSENSE			-14.4	dBm	1
Receiver Overload (OMA)	Pmax	1			dBm	
Optical Return Loss				-26	dB	
LOS Assert	LOSA	-30			dBm	
LOS De-Assert LOS	LOSD			-17	dBm	
LOS Hysteresis		0.5			dB	

Note: Measured at 25.78125Gb/s, ER>=3.5dBm, PRBS 2³¹-1 and BER better than or equal to 5E⁻⁵.

Electric Ports Definition

Parameter	Symbol	Min	Typ.	Max	Unit	Note
Transmitter						
Input Differential Impedance	R _{IN}		100		Ω	
Single-ended Data Input Swing	V _{IN}	90		450	mVp-p	
Transmit Disable Voltage	V _{DIS}	2		V _{CCHOST}	V	
Transmit Enable Voltage	V _{EN}	V _{EE}		V _{EE} +0.8	V	
Transmit Fault Assert Voltage	V _{FA}	2		V _{CCHOST}	V	
Transmit Fault De-Assert Voltage	V _{FDA}	V _{EE}		V _{EE} +0.4	V	
Receiver						
Single-ended Data Output Swing	V _{OD}	200		450	mVp-p	
LOS Fault	V _{LOSFT}	2		V _{CCHOST}	V	
LOS Normal	V _{LOSNR}	V _{EE}		V _{EE} +0.4	V	

Digital Diagnostic Monitor Accuracy

Parameter	Accuracy	Unit
Internally Measured Transceiver Temperature	+/-3	°C
Internally Measured Transceiver Supply Voltage	+/-3	%
Measured Tx Bias Current	+/-10	%
Measured Tx Output Power	+/-3	dB
Measured Rx Received Average Optical Power	+/-3	dB

Ordering Information

Product Name	Product Description
DFPP-LP-C27-25	CWDM 25G SM 10KM 1271nm DDM LC interface
DFPP-LP-C29-25	CWDM 25G SM 10KM 1291nm DDM LC interface
DFPP-LP-C31-25	CWDM 25G SM 10KM 1311nm DDM LC interface
DFPP-LP-C33-25	CWDM 25G SM 10KM 1331nm DDM LC interface
DFPP-LP-C35-25	CWDM 25G SM 10KM 1351nm DDM LC interface
DFPP-LP-C37-25	CWDM 25G SM 10KM 1371nm DDM LC interface

Contact Information



Ascent Communication Technology Ltd

AUSTRALIA

140 William Street, Melbourne
Victoria 3000, AUSTRALIA
Phone: +61-3-8691 2902

Hong Kong SAR

Room 1210, 12th Floor, Wing Tuck Commercial Centre
181 Wing Lok Street, Sheung Wan , Hong Kong SAR
Phone: +852-2851 4722

CHINA

Unit 1933, 600 Luban Road
200023, Shanghai, CHINA
Phone: +86-21-60232616

USA

2710 Thomes Ave
Cheyenne, WY 82001, USA
Phone: +1 203 350 9822

EUROPE

Pfarrer-Bensheimer-Strasse 7a
55129 Mainz, GERMANY
Phone: +49 (0) 6136 926 3246

VIETNAM

11th Floor, Hoa Binh Office Tower
106 Hoang Quoc Viet Street, Nghia Do Ward
Cau Giay District, Hanoi 10649, VIETNAM
Phone: +84-24-37955917

WEB: www.ascentcomtec.com

EMAIL: sales@ascentcomtec.com

Specifications and product availability are subject to change without notice.
Copyright © 2026 Ascent Communication Technology Limited. All rights reserved.
Ver. ACT_DFPP-LP-CXX-25_Datasheet_V1c_Apr_2026