

10 Gb/s CWDM SFP+ 10 km Transceiver

SFP+ Series



- **10Gb/s serial optical interface compliant to 802.3ae**
- **CWDM DFB transmitter, PIN photo-detector**
- **II-metal housing for superior EMI performance**
- **Power consumption \leq 1.5W**
- **Advanced firmware**
- **Cost effective SFP+ solution**
- **RoHS Compliant**

The DFPP-LP-CXX-10 is a high-performance 10G CWDM SFP+ transceiver engineered for optical data transmission and reception over single-mode fiber links up to 10 kilometers. Designed for demanding 10GBASE-LR applications, this module features a CWDM DFB laser and complies with SFI electrical specifications, ensuring robust signal integrity and minimal EMI through differential AC coupling and high-quality termination.

The transceiver's transmitter section converts high-speed electrical data into optical signals, featuring an internal Automatic Power Control (APC) loop that maintains consistent optical output despite voltage or temperature changes. It includes important safety and diagnostic functions, such as TX_Disable and TX_Fault indicators, providing system-level control and real-time fault detection. These functions help ensure reliable operation and simplify integration into network equipment.

On the receiving end, the module transforms incoming 10Gbps optical signals into PECL/CML electrical outputs, with a built-in Loss of Signal (Rx_LOS) feature that alerts the host system to degraded or absent signal conditions. This makes the DFPP-LP-CXX-10 ideal for ensuring high data integrity in long-reach optical links, helping identify issues such as disconnected cables or non-functioning transmitters. Overall, it offers a compact and efficient solution for CWDM optical networking with a strong emphasis on stability, reliability, and compliance with industry standards.

Key Features

- 10Gb/s serial optical interface compliant to 802.3ae 10GBASE-LR
- Electrical interface compliant to SFF-8431
- Small Form Factor Pluggable compliant to SFF-8432
- LC Duplex connector
- CWDM DFB transmitter, PIN photo-detector
- 2-wire interface for management specifications compliant with SFF 8472 digital diagnostic monitoring interface for optical transceivers
- Low EMI
- Low power consumption
- Advanced firmware allow customer system encryption information to be stored in transceiver
- Cost effective SFP+ solution, enables higher port densities and greater bandwidth
- RoHS compliant
- Operating case temperature range:
Commercial: 0 to 70 °C
Industrial: -40 to 85 °C

Mechanical Dimensions

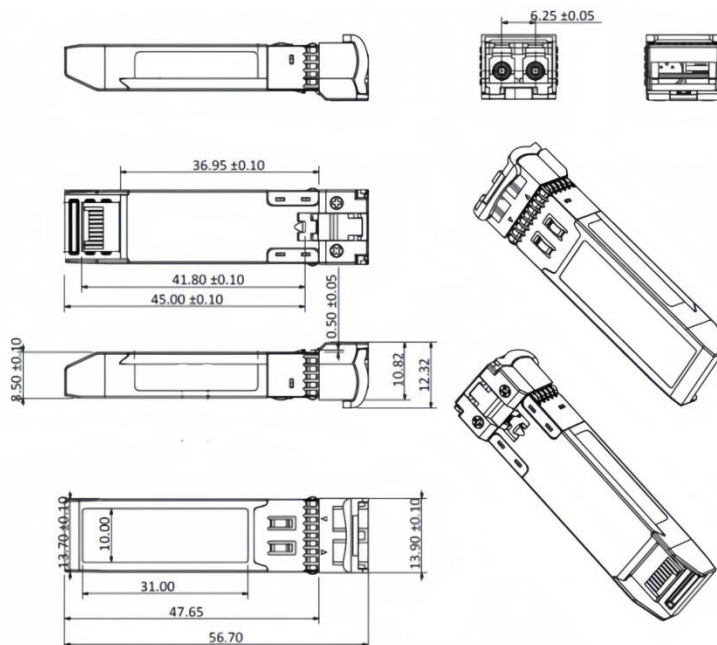

Proposed Application Schematics

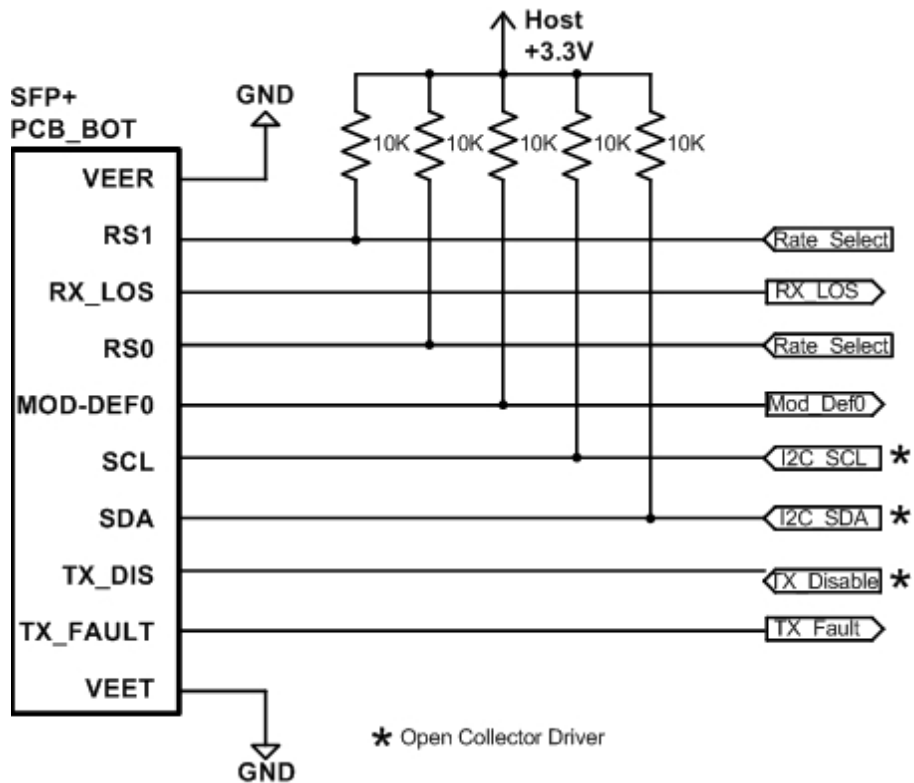
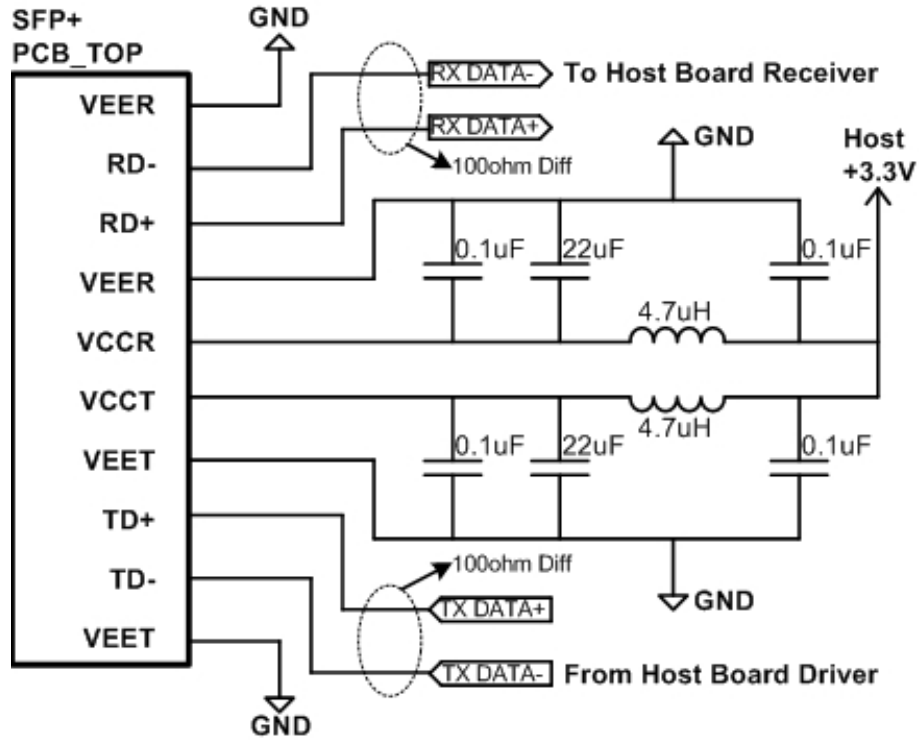

Transceiver Block Diagram

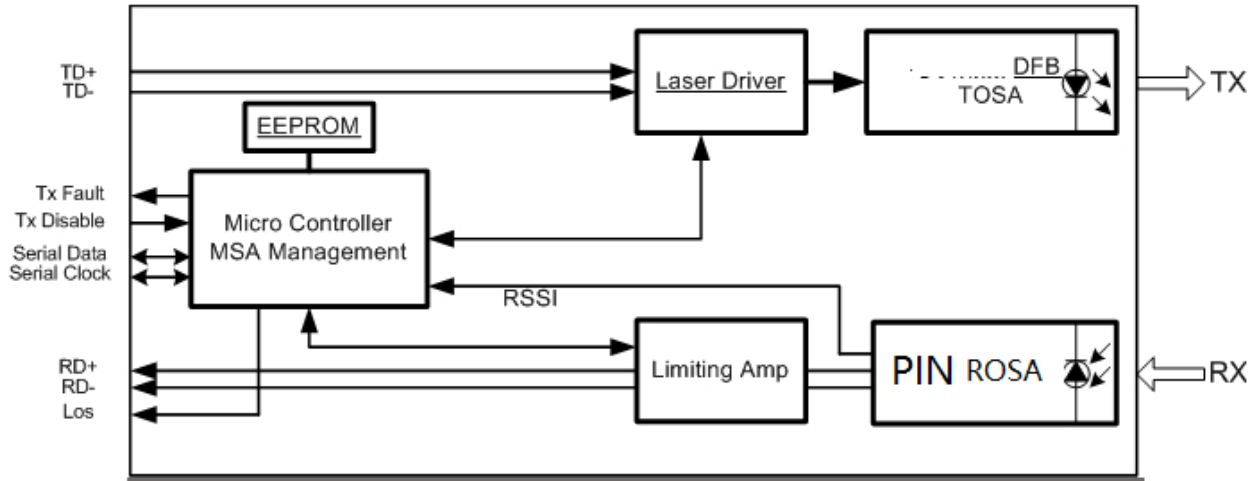

Pin Assignment

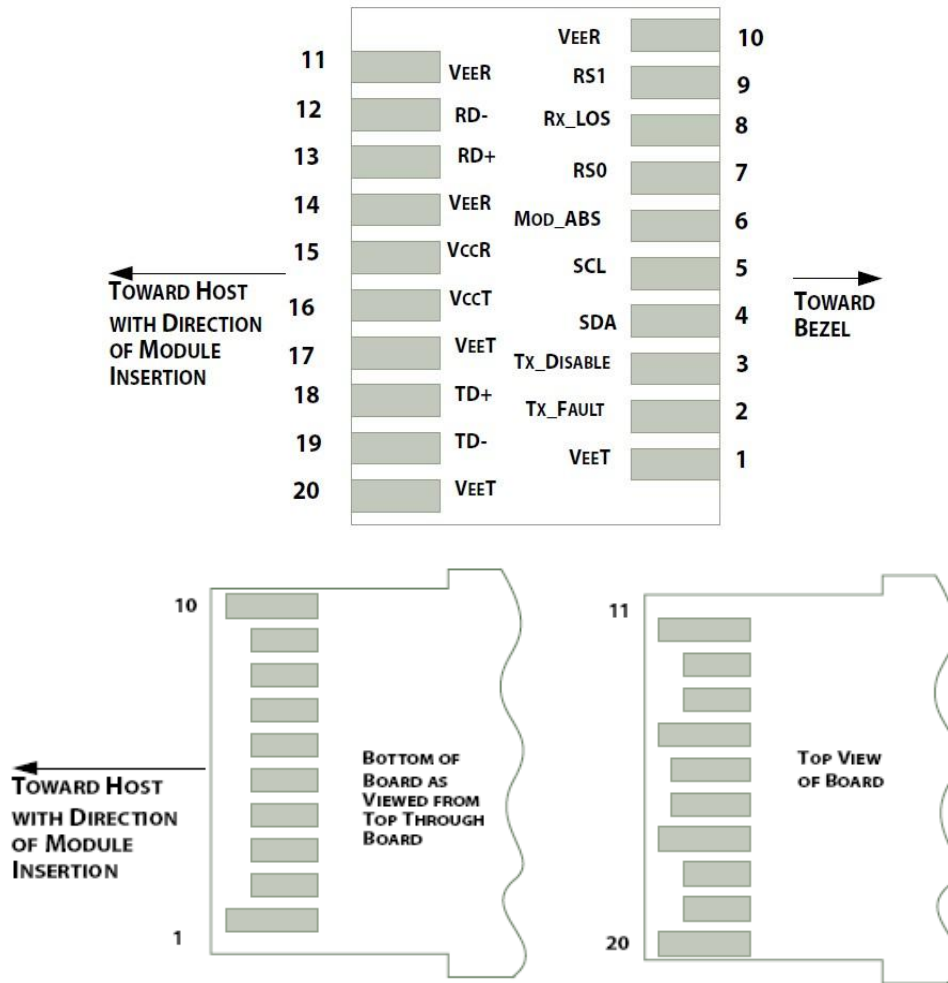

Pin	Logic	Symbol	Description	Notes
1		VeeT	Module Transmitter Ground	1
2	LVTTL-O	TX_Fault	Module Transmitter Fault	
3	LVTTL-I	TX_Dis	Transmitter Disable; Turns off transmitter laser output	
4	LVTTL-I/O	SDA	2-Wire Serial Interface Data Line	2
5	LVTTL-I	SCL	2-Wire Serial Interface Clock	2
6		MOD_DEF0	Module Definition, Grounded in the module	
7	LVTTL-I	RS0	Receiver Rate Select	
8	LVTTL-O	RX_LOS	Receiver Loss of Signal Indication Active LOW	
9	LVTTL-I	RS1	Transmitter Rate Select (not used)	
10		VeeR	Module Receiver Ground	1
11		VeeR	Module Receiver Ground	1
12	CML-O	RD-	Receiver Inverted Data Output	
13	CML-O	RD+	Receiver Data Output (not used)	
14		VeeR	Module Receiver Ground	1

Pin	Logic	Symbol	Description	Notes
15		VccR	Module Receiver 3.3 V Supply	
16		VccT	Module Receiver 3.3 V Supply	
17		VeeT	Module Transmitter Ground	1
18	CML-I	TD+	Transmitter Non-Inverted Data Input	
19	CML-I	TD-	Transmitter Inverted Data Input	
20		VeeT	Module Transmitter Ground	1

Notes:

1. Module ground pins GND are isolated from the module case.
2. Shall be pulled up with 4.7K to 10Kohms to a voltage between 3.15V and 3.45V on the host board.

Specifications

Recommended Operating Conditions

Recommended Operating Environment specifies parameters for which the electrical and optical characteristics hold unless otherwise noted.

Parameter	Symbol	Min.	Typ.	Max.	Unit	Note
Power Supply Voltage	V _{cc}	3.135	3.3	3.465	V	
Power Supply Current	I _{cc}			350	mA	
Operating Case Temperature	T _C	0	25	70	°C	
Relative Humidity	RH	5		95		%

Optical Characteristics

Parameter	Values	Unit
Operating Reach	10	km
Transmitter		
Center Wavelength (Range)	1391, 1411, 1431, 1451, 1471, 1491, 1511, 1531, 1551, 1571, 1591, 1611	nm
Side Mode Suppression Ratio (Min)	30	dB
Output Power	0 to 6	dBm
Average Launch Power	0 to 6	dBm
Transmitter and Dispersion Penalty (Max)	3.2	dB
Average Launch Power of OFF Transmitter (Max)	-30	dBm
Extinction Ratio (Min)	3.5	dB
RIN12 OMA (Max)	-128	dB/Hz
Optical Return Loss Tolerance (min)	12	dB

Receiver

Parameter	Values	Unit
Center Wavelength (Range)	1391, 1411, 1431, 1451, 1471, 1491, 1511, 1531, 1551, 1571, 1591, 1611	nm
Receive Overload (Max) in Average Power (Note 1)	0.5	dBm
Receive Sensitivity (Min) in Average Power (Note 2)	-14.4	dBm
Receiver Reflectance (Max)	-12	dB
Los Assert (Min)	-30	dBm
Los Dessert (Max)	-15	dBm
Los Hysteresis(min)	0.5	dB
Receive Electrical 3dB Upper Cutoff Frequency (Max)	12.3	dBm
Receiver Power (Damage, Max)	+7	dBm

Notes:

1. Average optical power shall be measured using the methods specified in TIA/EIA-455-95.
2. Measured with a PRBS 2³¹-1 test pattern, @ 10.325 Gb/s, BER≤10⁻¹².
3. Path penalty is intended as the power penalty of the interface between back-to-back and the maximum applied dispersion.

Electrical Characteristics

The following electrical characteristics are defined over the Recommended Operating Environment unless otherwise specified.

Parameter	Symbol	Min.	Typ.	Max.	Unit	Note
Data Rate		9.95	10.3125	11.3	Gbps	
Power Consumption				1.5	mW	
Transmitter						
Single Ended Output Voltage Tolerance		-0.3		4	V	
C common Mode Voltage Tolerance		15			mV	
Tx Input Diff Voltage	VI	180		800	mV	
Tx Fault	VoL	-0.3		0.4	V	At 0.7mA
Data Dependent Input Jitter	DDJ			0.1	UI	
Data Input Total Jitter	TJ			0.28	UI	
Receiver						
Single Ended Output Voltage Tolerance		-0.3		4	V	
Rx Output Diff Voltage	Vo	300		850	mV	
Rx Output Rise and Fall Time	Tr/Tf	30			ps	20% to 80%
Total Jitter	TJ			0.7	UI	
Deterministic Jitter	DJ			0.42	UI	

Control and Status I/O Timing Characteristics

Timing characteristics of control and status I/O are included in Pin Description table, which is also defined in SFF-8431.

Parameter	Symbol	Min.	Typ.	Max.	Unit	Note
TX Disable Assert Time	t _{off}			10	μs	Time from rising edge of TX Disable to when the optical output falls below 10% of nominal
TX Disable Negate Time	t _{on}			1	ms	Time from falling edge of TX Disable to when the modulated optical output rises above 90% of nominal
Time to Initialize, including Reset of TX_Fault	t _{init}			300	ms	From power on or negation of TX Fault using TX Disable
TX Fault Assert Time	t _{fault}			100	μs	Time from fault to TX fault on
TX Disable to Reset	t _{reset}	10			μs	Time TX Disable must be held high to reset TX fault

LOS Assert Time	t_loss_on	100	μs	Time from LoS state to RX LOS assert
LOS Deassert Time	t_loss_off	100	μs	Time from non-LOS state to RX LOS deassert
Rate-Select Change Time	t_ratesel	10	μs	Time from rising or falling edge of Rate Select input until receiver bandwidth is in conformance with appropriate specification
Serial ID Clock Rate	t_serial_clock	100	kHz	

Digital Diagnostic Functions

The following digital diagnostic characteristics are defined over the Recommended Operating Environment unless otherwise specified. It is compliant to SFF8472 Rev10.2 with internal calibration mode. For external calibration mode please contact our sales staff.

Parameter	Symbol	Min	Typ.	Max	Unit	Note
Temperature Monitor Absolute Error	DMI_Temp	-3		3	°C	Over operating temp
Laser Power Monitor Absolute Error	DMI_TX	-3		3	dB	
RX Power Monitor Absolute Error	DMI_RX	-3		3	dB	-7dBm to -20dBm range
Supply Voltage Monitor Absolute Error	DMI_VCC	-0.08		0.08	V	Full operating range
Bias Current Monitor	DMI_Ibias	-10%		10%	mA	

Digital Diagnostic Monitor Accuracy

The following characteristics are defined over recommended operating condition.

Parameter	Range	Accuracy	Unit	Calibration
Temperature	0 to 70	±3	°C	Internal
Voltage	0 to Vcc	±3%	V	Internal
Tx Bias Current	0 to 100	±10%	mA	Internal
Tx Output Power	0 to 6	±3	dBm	Internal
Rx Input Power	-15 to 0	±3	dBm	Internal

ESD

This transceiver is specified as ESD threshold 2kV for all electrical input pins, tested per MIL-STD-883, Method 3015.4 /JESD22-A114-A (HBM). However, normal ESD precautions are still required during the handling of this module. This transceiver is shipped in ESD protective packaging. It should be removed from the packaging and handled only in an ESD protected environment.

Laser Safety

This is a Class 1 Laser Product according to IEC 60825-1:1993:+A1:1997+A2:2001. This product complies with 21 CFR 1040.10 and 1040.11 except for deviations pursuant to Laser Notice No. 50, dated (July 26, 2001).

Ordering Information

Product Name	Product Description
DFPP-LP-C39-10	CWDM 10G SM 10KM 1391nm DDM LC interface
DFPP-LP-C41-10	CWDM 10G SM 10KM 1411nm DDM LC interface
DFPP-LP-C43-10	CWDM 10G SM 10KM 1431nm DDM LC interface
DFPP-LP-C45-10	CWDM 10G SM 10KM 1451nm DDM LC interface
DFPP-LP-C47-10	CWDM 10G SM 10KM 1471nm DDM LC interface
DFPP-LP-C49-10	CWDM 10G SM 10KM 1491nm DDM LC interface
DFPP-LP-C51-10	CWDM 10G SM 10KM 1511nm DDM LC interface
DFPP-LP-C53-10	CWDM 10G SM 10KM 1531nm DDM LC interface
DFPP-LP-C55-10	CWDM 10G SM 10KM 1551nm DDM LC interface
DFPP-LP-C57-10	CWDM 10G SM 10KM 1571nm DDM LC interface
DFPP-LP-C59-10	CWDM 10G SM 10KM 1591nm DDM LC interface
DFPP-LP-C61-10	CWDM 10G SM 10KM 1611nm DDM LC interface

Contact Information

Ascent Communication Technology Ltd

AUSTRALIA

140 William Street, Melbourne
Victoria 3000, AUSTRALIA
Phone: +61-3-8691 2902

CHINA

Unit 1933, 600 Luban Road
200023, Shanghai, CHINA
Phone: +86-21-60232616

EUROPE

Pfarrer-Bensheimer-Strasse 7a
55129 Mainz, GERMANY
Phone: +49 (0) 6136 926 3246

WEB: www.ascentcomtec.com

Hong Kong SAR

Room 1210, 12th Floor, Wing Tuck Commercial Centre
181 Wing Lok Street, Sheung Wan , Hong Kong SAR
Phone: +852-2851 4722

USA

2710 Thomes Ave
Cheyenne, WY 82001, USA
Phone: +1 203 350 9822

VIETNAM

11th Floor, Hoa Binh Office Tower
106 Hoang Quoc Viet Street, Nghia Do Ward
Cau Giay District, Hanoi 10649, VIETNAM
Phone: +84-24-37955917

EMAIL: sales@ascentcomtec.com

Specifications and product availability are subject to change without notice.
Copyright © 2026 Ascent Communication Technology Limited. All rights reserved.
Ver. ACT_DFPP-LP-CXX-10_Datasheet_V1c_Apr_2026