

40 Gb/s QSFP+ PSM 1310nm 10km MPO Optical Transceiver

QSFP Series

- Four-channel full-duplex transceiver modules
- Transmission data rate up to 11.2 Gbit/s per channel
- Up to 10 km transmission distance with SMF
- DFB laser array inside
- Low power consumption
- RoHS 6 compliant
- Hot-pluggable QSFP form factor
- Single MPO connector receptacle
- Built-in digital diagnostic



Ascent's QSFP-AQ-MP-31-10 is a four-channel, hot-pluggable, parallel, fiber-optic QSFP+ transceiver for InfiniBand QDR/DDR/SDR, 10G/8G/4G/2G fiber channel and SAS applications. It is compliant with the QSFP+ MSA, IEEE 802.3ae 10GBASE-LR/LW, and OTN data rates OTU2, OTU1e, and OTU2e per the ITU and designed for use in high density 10 Gigabit Ethernet links over single mode fiber.

The QSFP full-duplex optical module offers 4 independent transmit and receive channels, each capable of 10.3 Gbps operation for an aggregate data rate of 40 Gbps over 10 km using single-mode fiber. These modules are designed to operate over single-mode fiber systems using a 1310 nm DFB laser array.

An optical fiber ribbon cable with an MPO/MTPTM connector can be plugged into the QSFP module receptacle. QSFP+ PSM LR4 is one kind of parallel transceiver which provides increased port density and total system cost savings.

Key Features

- Four-channel full-duplex transceiver modules
- Transmission data rate up to 11.2 Gbit/s per channel
- Up to 10 km transmission distance with single-mode fiber
- DFB laser array inside
- <2.5 W power consumption
- Operating case temperature: 0°C to +70°C
- 3.3 V power supply voltage
- RoHS 6 compliant
- Hot-pluggable QSFP form factor
- Single MPO connector receptacle
- Built-in digital diagnostic function

Outline Dimensions

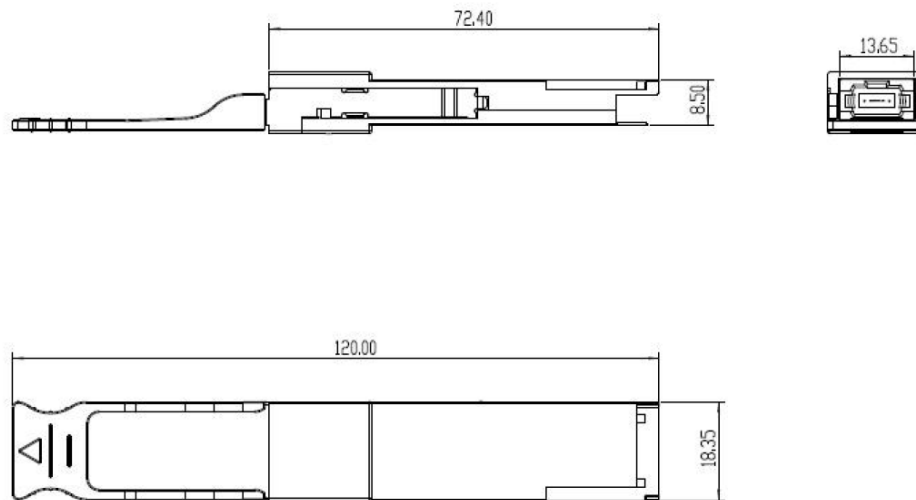

Pin Assignment

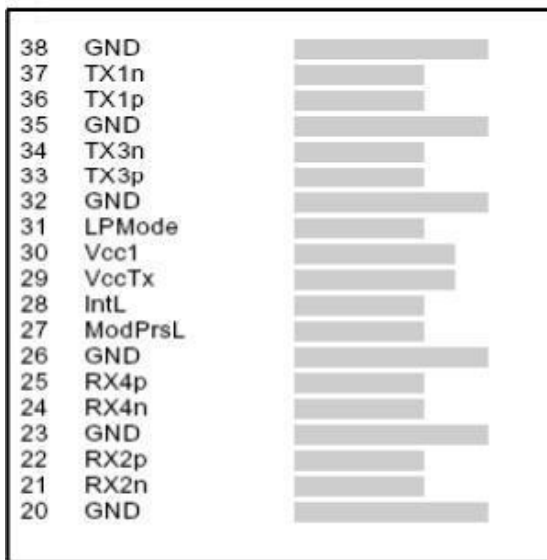

Top side

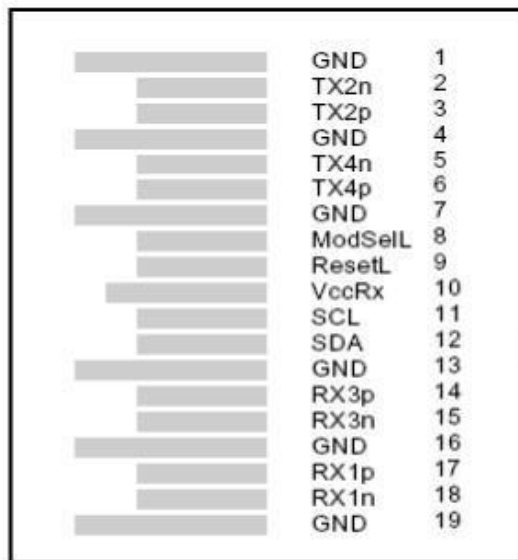

Bottom side

| Pin | Symbol | Name/Description | Notes |
|-----|---------|-------------------------------------|--------------|
| 1 | GND | Ground | 1 |
| 2 | Tx2n | Transmitter Inverted Data Input | |
| 3 | Tx2p | Transmitter Non-Inverted Data Input | |
| 4 | GND | Ground | 1 |
| 5 | Tx4n | Transmitter Inverted Data Input | |
| 6 | Tx4p | Transmitter Non-Inverted Data Input | |
| 7 | GND | Ground | 1 |
| 8 | ModSelL | Module Select | 1 |
| 9 | ResetL | Module Reset | |
| 10 | Vcc Rx | +3.3 V Power supply receiver | |
| 11 | SCL | 2-wire serial interface clock | |
| 12 | SDA | 2-wire serial interface data | |
| 13 | GND | Ground | 1 |
| 14 | Rx3p | Receiver Non-Inverted Data Output | |
| 15 | Rx3n | Receiver Inverted Data Output | |
| 16 | GND | Ground | 1 |
| 17 | Rx1p | Receiver Non-Inverted Data Output | |
| 18 | Rx1n | Receiver Inverted Data Output | |
| 19 | GND | Ground | 1 |
| 20 | GND | Ground | 1 |
| 21 | Rx2n | Receiver Inverted Data Output | |
| 22 | Rx2p | Receiver | Non-Inverted |
| 22 | Rx2p | Receiver Non-Inverted Data Output | |
| 23 | GND | Ground | 1 |
| 24 | Rx4n | Receiver Inverted Data Output | |
| 25 | Rx4p | Receiver Non-Inverted Data Output | |
| 26 | GND | Ground | 1 |

| Pin | Symbol | Name/Description | Notes |
|-----|---------|-------------------------------------|-------|
| 27 | ModPrsL | Module Present | |
| 28 | IntL | Interrupt | |
| 29 | Vcc Tx | +3.3 V Power supply transmitter | |
| 30 | Vcc1 | +3.3 V Power Supply | |
| 31 | LPMODE | Low Power Mode | |
| 32 | GND | Ground | 1 |
| 33 | Tx3p | Transmitter Non-Inverted Data Input | |
| 34 | Tx3n | Transmitter Inverted Data Input | |
| 35 | GND | Ground | 1 |
| 36 | Tx1p | Transmitter Non-Inverted Data Input | |
| 37 | Tx1n | Transmitter Inverted Data Input | |
| 38 | GND | Ground | 1 |

Notes:

1. Circuit ground is internally isolated from chassis ground.

Other Pin Descriptions:

ModSelL Pin

The ModSelL is an input pin. When held low by the host, the module responds to 2-wire serial communication commands. The ModSelL allows the use of multiple QSFP modules on a single 2-wire interface bus. When the ModSelL is “High”, the module will not respond to any 2-wire interface communication from the host. ModSelL has an internal pull-up in the module.

ResetL Pin

Reset. LPMODE_Reset has an internal pull-up in the module. A low level on the ResetL pin for longer than the minimum pulse length (t_Reset_init) initiates a complete module reset, returning all user module settings to their default state. Module Reset Assert Time (t_init) starts on the rising edge after the low level on the ResetL pin is released. During the execution of a reset (t_init) the host shall disregard all status bits until the module indicates a completion of the reset interrupt. The module indicates this by posting an IntL signal with the Data_Not_Ready bit negated. Note that on power up (including hot insertion) the module will post this completion of reset interrupt without requiring a reset.

LPMODE Pin

Ascent PSM IR4 operate in the low power mode (<1.5 W power consumption) This pin active high will decrease power consumption to less than 1W.

ModPrsL Pin

ModPrsL is pulled up to Vcc on the host board and grounded in the module. The ModPrsL is asserted “Low” when the module is inserted and deasserted “High” when the module is physically absent from the host connector.

IntL Pin

IntL is an output pin. When “Low”, it indicates a possible module operational fault or a status critical to the host system. The host identifies the source of the interrupt by using the 2-wire serial interface. The IntL pin is an open collector output and must be pulled up to Vcc on the host board.

Power Supply Filtering

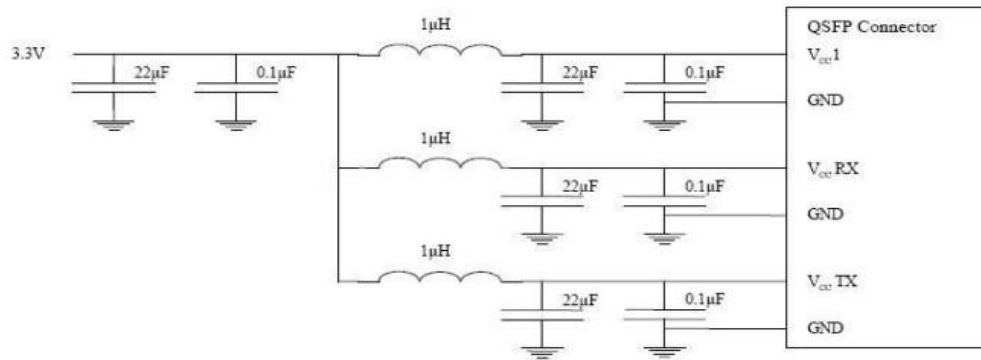

Optical Interface Lanes and Assignment

The optical interface port is a male MPO connector. The four fiber positions on the left as shown in below, with the key up, are used for the optical transmit signals (channels 1 through 4). The fiber positions on the right are used for the optical receive signals (channels 4 through 1). The central four fibers are physically present.

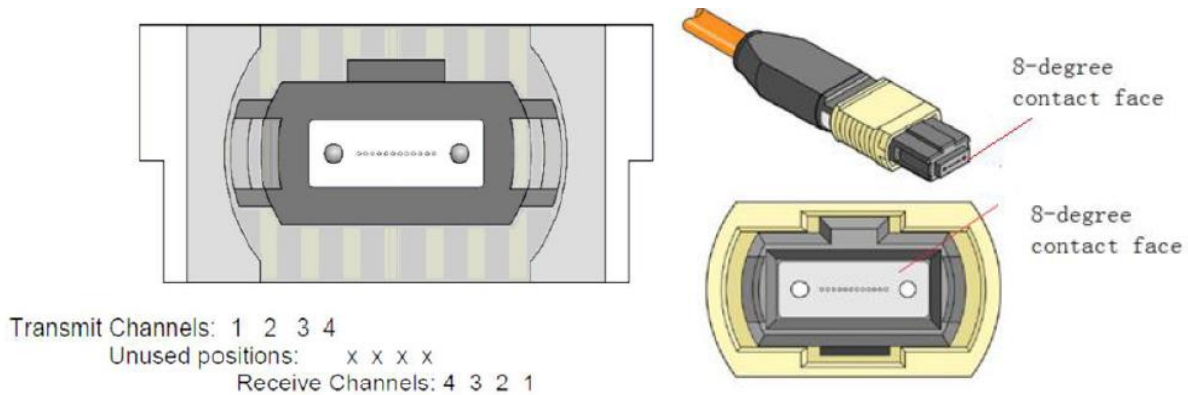

Specifications

Absolute Maximum Ratings

| Parameter | Symbol | Min. | Typ. | Max. | Unit | Note |
|----------------------------|-----------------|------|------|------|------|------|
| Supply Voltage | V _{CC} | -0.3 | | 3.6 | V | |
| Storage Temperature | T _S | -40 | | 85 | °C | |
| Relative Humidity | RH | 0 | | 85 | % | |
| Damage Threshold, per Lane | DT | 3.4 | | | dBm | |

Note: Stress in excess of the maximum absolute ratings can cause permanent damage to the transceiver.

General Operating Characteristics

| Parameter | Symbol | Min | Typ. | Max | Unit | Note |
|-------------------|-----------------|-----|------|--------|------|------|
| Bit Rate per Lane | B _R | | | 10.313 | Gb/s | 1 |
| Bit Error Ratio | B _{ER} | | | 10-12 | | 2 |
| Distance on SMF | D ₁ | | | 10 | km | 3 |

Notes:

1. Compliant with 40G Ethernet. Compatible with 1/10 Gigabit Ethernet and 1/2/4/8/10G Fiber Channel.
2. Tested with a PRBS 2³¹-1 test pattern.
3. Per 40GBASE-LR4, IEEE 802.3ba.

Optical Characteristics (T_{OP(C)} = 0 °C to +70 °C, V_{CC} = 3.13 V to 3.47 V)

| Parameter | Symbol | Min. | Typ. | Max. | Unit | Note |
|--|-----------------------------------|------|------|-------|------|------|
| Transmitter | | | | | | |
| Operating Wavelength | λ _C | 1270 | 1310 | 1350 | nm | |
| Average Output Power | P _{AVE} | -5.2 | | +1 | dBm | |
| Difference in Launch Power between any Two Lanes (OMA) | D _L | | | 5 | dB | |
| Extinction Ratio | E _R | 3.5 | | | dB | |
| Peak Power, each Lane | P _P | | | 4 | dBm | |
| Dispersion Penalty, each Lane | T _{DP} | | | 3.5 | dB | |
| Average Launch Power of OFF Transmitter, each Lane | P _{OFF} | | | -30 | dB | |
| Eye Mask Coordinates: X1, X2, X3, Y1, Y2, Y3 | Specification values | | | | | 1 |
| | 0.23, 0.34, 0.43, 0.27, 0.35, 0.4 | | | | | |
| Receiver | | | | | | |
| Operating Wavelength | λ _C | 1270 | | 1350 | nm | |
| Stressed Receiver Sensitivity in OMA | P _{SEN1} | | | -12.5 | dBm | 2 |
| Average Receive Power, each Lane | P _{AVE} | -11 | | +2.4 | dBm | |
| Receiver Reflectance | R _{RX} | | | -12 | dB | |
| LOS Assert | P _a | -30 | | | dBm | |
| LOS De-Assert | P _d | | | -15 | dBm | |
| LOS Hysteresis | P _d -P _a | 0.5 | | | dB | |

Notes:

1. Hit ratio = 5×10^{-5}
2. Measured with conformance test signal at TP3 for BER = 10⁻¹² Receiver Characteristics.

Ordering Information

Product Name

QSFP-AQ-MP-31-10

Product Description

QSFP+ Plug-in, 4x10Gbps, PLR4, 10km, 1310nm on single mode fiber, MPO-12

Contact Information



Ascent Communication Technology Ltd

AUSTRALIA

140 William Street, Melbourne
Victoria 3000, AUSTRALIA
Phone: +61-3-8691 2902

Hong Kong SAR

Room 1210, 12th Floor, Wing Tuck Commercial Centre
181 Wing Lok Street, Sheung Wan , Hong Kong SAR
Phone: +852-2851 4722

CHINA

Unit 1933, 600 Luban Road
200023, Shanghai, CHINA
Phone: +86-21-60232616

USA

2710 Thomes Ave
Cheyenne, WY 82001, USA
Phone: +1 203 350 9822

EUROPE

Pfarrer-Bensheimer-Strasse 7a
55129 Mainz, GERMANY
Phone: +49 (0) 6136 926 3246

VIETNAM

11th Floor, Hoa Binh Office Tower
106 Hoang Quoc Viet Street, Nghia Do Ward
Cau Giay District, Hanoi 10649, VIETNAM
Phone: +84-24-37955917

WEB: www.ascentcomtec.com

EMAIL: sales@ascentcomtec.com

Specifications and product availability are subject to change without notice.
Copyright © 2026 Ascent Communication Technology Limited. All rights reserved.
Ver. ACT_QSFP-AQ-MP-31-10_Datasheet_V1c_May_2019