

Cabinet 1 or 2-port Optical Node FTTx Solution

AON1210 Series

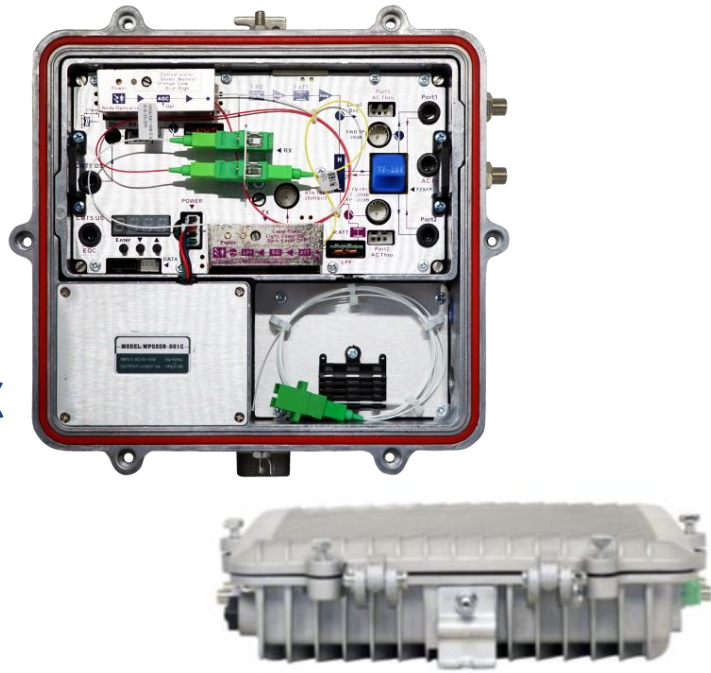

- **Deep Fibre Node with 1 or 2 High Outputs**
- **Compact Housing**
- **Suitable for MDU Application**
- **Max Output Level 2x 108 dB μ V**
- **GaAs amplifier device**
- **Excellent AGC performance**
- **Reserved data communication interface**
- **Burst mode for return transmissions optional**

AON1210 Series 1- or 2-port two-way Optical Node is part of ACT Deep Fiber solution, which has been designed to deliver interactive CATV, high capacity DOCSIS Data and other advanced services. The cost-effective node platform helps service providers expand bandwidth of their existing HFC network while minimizing capital investment.

AON1210 is a 1GHz features a modular design for flexible applications. It has microprocessor control, a digital display, and an easy-to-use engineering debug interface. It has highly-optimized circuit design using SMT process production for smooth photoelectric signal transmissions. It has good RF attenuation with high accuracy with its use of a specialized RF attenuation chip. It uses GaAs technology to achieve high gains and low distortion, and has excellent AGC performance.

AON1210 node suits the last mile fiber deep access networks and also provides the optional HMS interface to support the remote monitoring capability in advanced network management system.

Key Features

- High response PIN photoelectric conversion tube
- Optimized circuit design, SMT process production, optimized signal path, make the photoelectric signal transmission smoother
- Specialized RF attenuation chip, with good RF attenuation and equilibrium linear, high accuracy
- GaAs amplifier device, power doubler output, with high gain and low distortion
- Single Chip Microcomputer (SCM) control equipment working, LCD display the parameters, convenience and intuitive operation, and stable performance
- Excellent AGC performance, when the input optical power range is -9 dBm to +2 dBm, the output level remains unchanged, CTB and CSO basically unchanged
- Reserved data communication interface, can connect with the Ethernet transponder, access to network management system
- Return emission can select burst mode to sharply decrease the noise convergence and reduce the forepart receiver number

Outline Dimensions

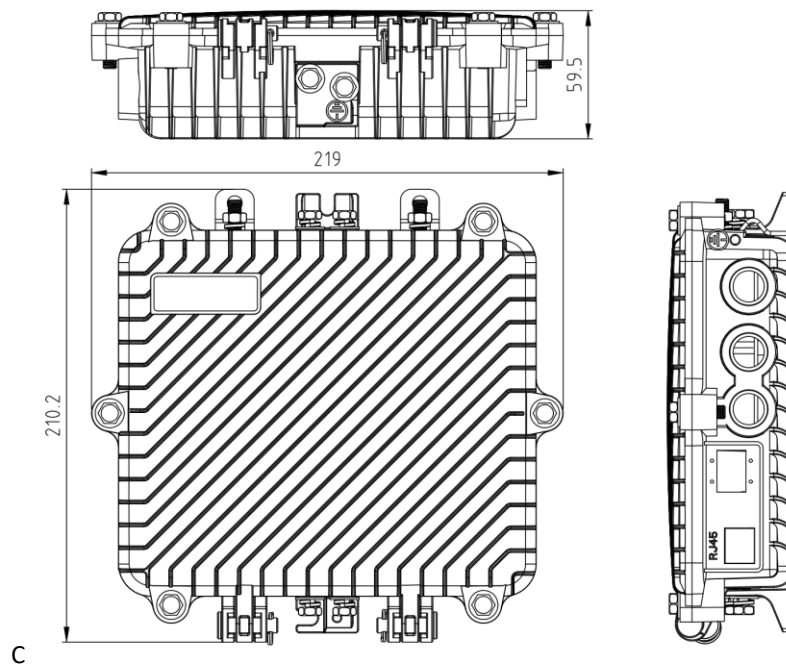

Block Diagram

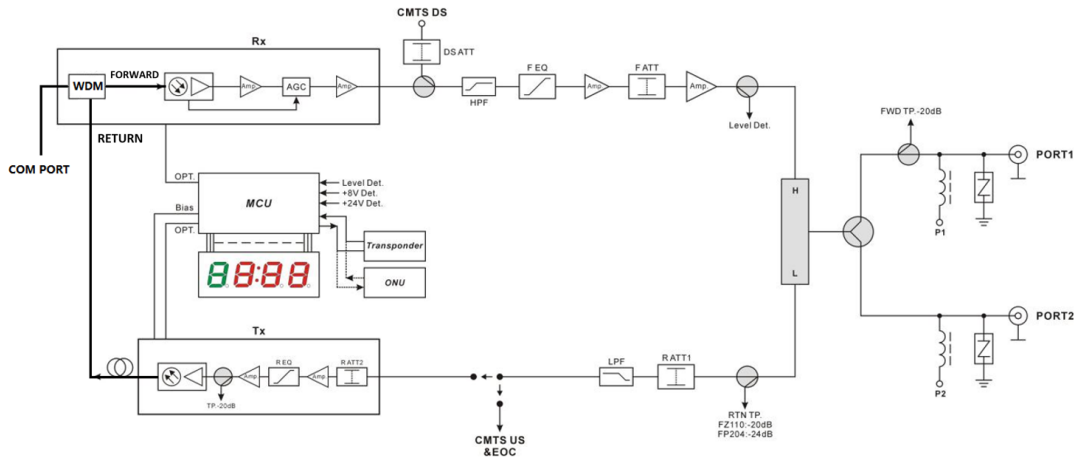

Single Fiber Option

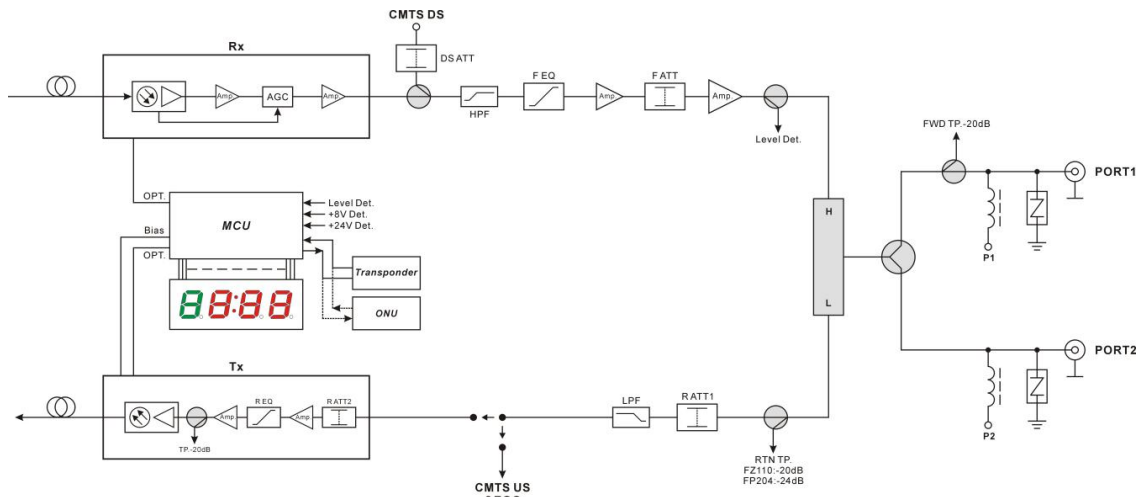

Dual Fiber Option

Specifications

Item	Unit	Technical Parameters	
Forward Optical Parameters			
Receiving Optical Power	dBm	-8 to +2	
Optical Return Loss	dB	>45	
Optical Receiving Wavelength	nm	1100 to 1600	
Optical Connector Type		FC/APC, SC/APC or specified by the user	
Fiber Type		Single Mode	
Link Performance			
C/N	dB	≥ 51 (-1dBm input)	
C/CTB	dB	≥ 65	Output Level 106dBμV
C/CSO	dB	≥ 60	EQ 8dB 79ch PAL-D
Forward RF Parameters			
Frequency Range	MHz	54/85/105/258-1003	
Flatness in Band	dB	±0.75	
Rated Output Level	dBμV	≥ 106	
Max Output Level	dBμV	≥ 108	
Output Return Loss	dB	(54/85/105/258 to 550MHz)≥16/(550 to 1003MHz)≥14	
Output Impedance	Ω	75	
Electronic Control EQ Range	dB	0 to 15	
Electronic Control ATT Range	dBμV	0 to 20	
Return Optical Parameters			
Optical Transmit Wavelength	nm	1310±10, 1550±10 or specified by the user	
Output Optical Power	mW	0.5, 1, 2	
Optical Connector Type		FC/APC, SC/APC or specified by the user	
Return RF Parameters			
Frequency Range	MHz	5 to 42/65/85/204	
Flatness in Band	dB	±0.75	
Input Level	dBμV	72 to 85	
Output Impedance	Ω	75	
NPR Dynamic Range	dB	≥15 (NPR≥30 dB)	≥10(NPR≥30 dB)
		Use DFB laser	Use FP laser
General Performance			
Supply Voltage	V	A: AC (150 to 265)V; B: AC (35 to 90)V	
Operating Temperature	°C	-40 to 60	
Storage Temperature	°C	-40 to 65	
Relative Humidity	%	Max 95% no condensation	
Consumption	VA	≤ 20	
Dimension (L×W×H)	mm	280 x 260 x 70	
Net Weight	kg	2.8	

Burst Mode (Optional)

Optical Output Power	dBm	-30
(When there is no burst signal input)		
Laser Turn On Threshold	dB μ V	≥ 70
Laser Turn Off Threshold	dB μ V	≤ 62
Laser Turn On Time (t1)	us	$0.5 \leq t1 \leq 1$
Laser Turn Off Time (t2)	us	$0.5 \leq t2 \leq 1.5$

Note: The forward RF parameters are tested under the condition of using GaAs 25dB power doubler module in the last stage. Use other module, the parameters will be slightly different.

Ordering Information

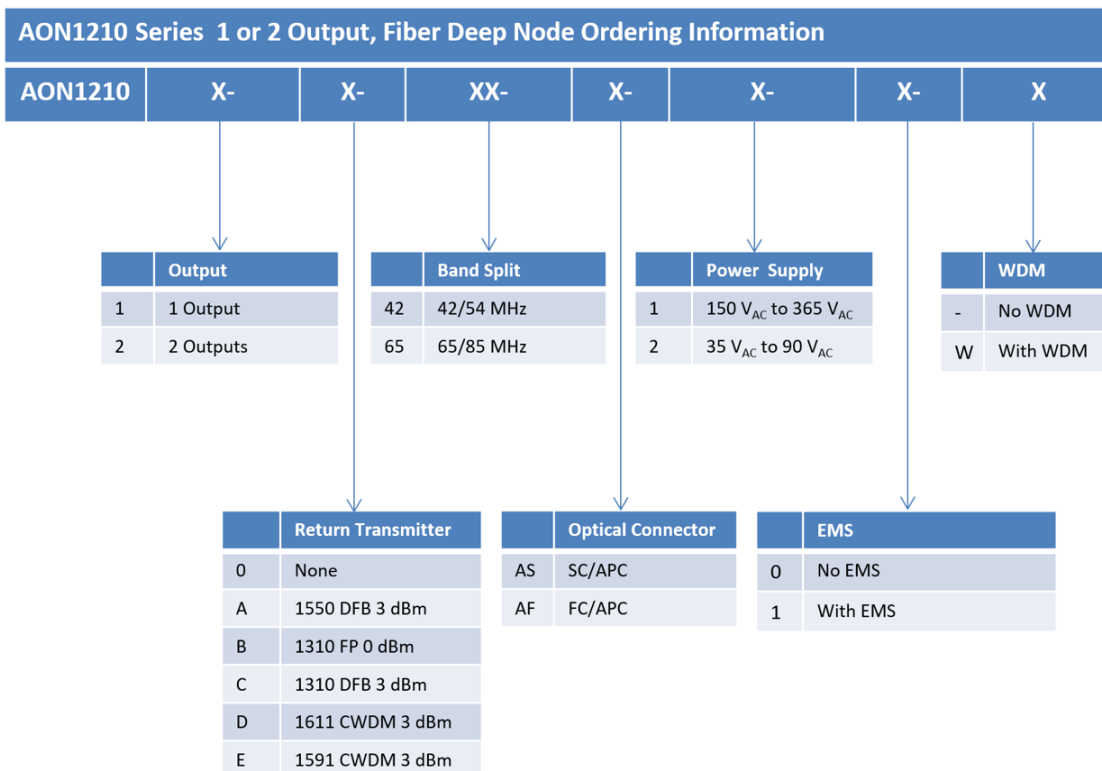

* Contact Ascent sales representative for single fiber WDM configuration.

** The optical connector and optional EMS RJ45 connector port are fixed inside of the housing.

Contact Information



Ascent Communication Technology Ltd

AUSTRALIA

140 William Street, Melbourne
Victoria 3000, AUSTRALIA
Phone: +61-3-8691 2902

Hong Kong SAR

Room 1210, 12th Floor, Wing Tuck Commercial Centre
181 Wing Lok Street, Sheung Wan, Hong Kong SAR
Phone: +852-2851 4722

CHINA

Unit 1933, 600 Luban Road
200023, Shanghai, CHINA
Phone: +86-21-60232616

USA

2710 Thomes Ave
Cheyenne, WY 82001, USA
Phone: +1 203 350 9822

EUROPE

Pfarrer-Bensheimer-Strasse 7a
55129 Mainz, GERMANY
Phone: +49 (0) 6136 926 3246

VIETNAM

11th Floor, Hoa Binh Office Tower
106 Hoang Quoc Viet Street, Nghia Do Ward
Cau Giay District, Hanoi 10649, VIETNAM
Phone: +84-24-37955917

WEB: www.ascentcomtec.com

EMAIL: sales@ascentcomtec.com

Specifications and product availability are subject to change without notice.
Copyright © 2026 Ascent Communication Technology Limited. All rights reserved.
Ver. ACT_AON1210_Series_Optical_Node_Datasheet_V2a_Mar_2024