

40G QSFP+ Active Optical Cable

- **Full Duplex 4 channel 850nm parallel active optical cable**
- **Up to 11.1 Gbps per channel**
- **Up to 300 m on OM3 MMF**
- **40G Ethernet**
- **QSFP+ MSA compliant**
- **RoHS compliant**
- **<1.5 W power consumption per cable end**



ASCENT 40G QSFP+ Active Optical Cable is a high-performance integrated cable suitable for high-speed core network and data center applications.

These optical cables are suitable for short-distance QSFP+ to QSFP+ data transmission and are a flexible way to connect switches within racks and across adjacent racks. Active optical cables are much thinner and lighter than copper cables, allowing for simpler installation. They also enable efficient system airflow, are protected from environmental pollutants, and have no electromagnetic interference (EMI) issues, which can be critical in high-density racks.

Compliant with QSFP+ MSA standards, these active optical cables offer a low-cost solution for data centers and high-performance computing, and can be seamlessly integrated with different fiber types.

Key Features

- Full duplex 4 channel 850 nm parallel active optical cable
- Up to 11.1 Gbps data rate per channel
- Maximum link length of 300m links on OM3 multi-mode fiber
- High-reliability 850 nm VCSEL technology
- Electrically hot-pluggable
- < 1.5 W power consumption per cable end
- QSFP+ MSA compliant
- RoHS compliant
- Case operating temperature range: 0 °C to +70 °C

Pin Assignment

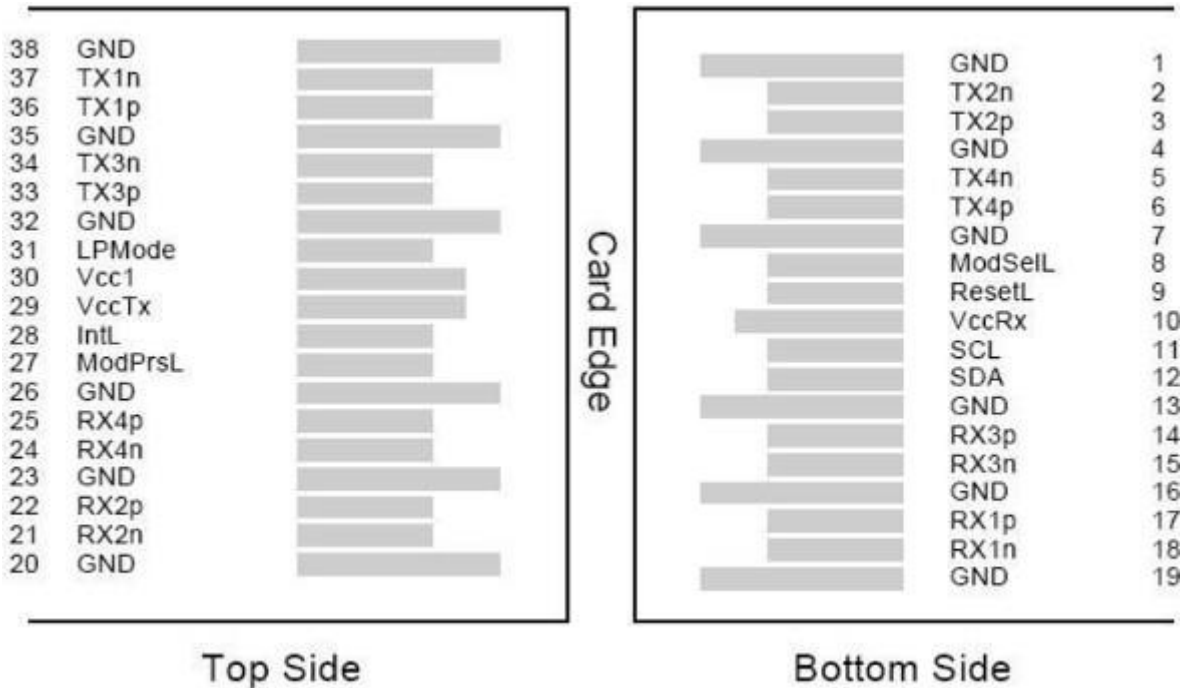

Pin out of Connector Block on Host Board

Pin	Symbol	Name/Description	NOTE
1	GND	Transmitter Ground (Common with Receiver Ground)	1
2	Tx2n	Transmitter Inverted Data Input	
3	Tx2p	Transmitter Non-Inverted Data Output	
4	GND	Transmitter Ground (Common with Receiver Ground)	1
5	Tx4n	Transmitter Inverted Data Input	
6	Tx4p	Transmitter Non-Inverted Data Output	

7	GND	Transmitter Ground (Common with Receiver Ground)	1
8	ModSelL	Module Select	
9	ResetL	Module Reset	
10	VccRx	3.3V Power Supply Receiver	2
11	SCL	2-Wire serial Interface Clock	
12	SDA	2-Wire serial Interface Data	
13	GND	Transmitter Ground (Common with Receiver Ground)	
14	Rx3p	Receiver Non-Inverted Data Output	
15	Rx3n	Receiver Inverted Data Output	
16	GND	Transmitter Ground (Common with Receiver Ground)	1
17	Rx1p	Receiver Non-Inverted Data Output	
18	Rx1n	Receiver Inverted Data Output	
19	GND	Transmitter Ground (Common with Receiver Ground)	1
20	GND	Transmitter Ground (Common with Receiver Ground)	1
21	Rx2n	Receiver Inverted Data Output	
22	Rx2p	Receiver Non-Inverted Data Output	
23	GND	Transmitter Ground (Common with Receiver Ground)	1
24	Rx4n	Receiver Inverted Data Output	1
25	Rx4p	Receiver Non-Inverted Data Output	
26	GND	Transmitter Ground (Common with Receiver Ground)	1
27	ModPrsl	Module Present	
28	IntL	Interrupt	
29	VccTx	3.3V Power Supply Transmitter	2
30	Vcc1	3.3V Power Supply	2
31	LPMMode	Low Power Mode, Not Connected	
32	GND	Transmitter Ground (Common with Receiver Ground)	1
33	Tx3p	Transmitter Non-Inverted Data Input	
34	Tx3n	Transmitter Inverted Data Output	
35	GND	Transmitter Ground (Common with Receiver Ground)	1
36	Tx1p	Transmitter Non-Inverted Data Input	
37	Tx1n	Transmitter Inverted Data Output	
38	GND	Transmitter Ground (Common with Receiver Ground)	1

Notes:

1. GND is the symbol for signal and supply (power) common for QSFP+ modules. All are common within the QSFP+ module and all module voltages are referenced to this potential unless otherwise noted. Connect these directly to the host board signal common ground plane.

2. VccRx, Vcc1, and VccTx are the receiving and transmitting power suppliers and shall be applied concurrently. Recommended host board power supply filtering is shown below. Vcc Rx, Vcc1, and Vcc Tx may be internally connected within the QSFP+ transceiver module in any combination. The connector pins are each rated for a maximum current of 500 mA.

Host - Transceiver Interface Block Diagram

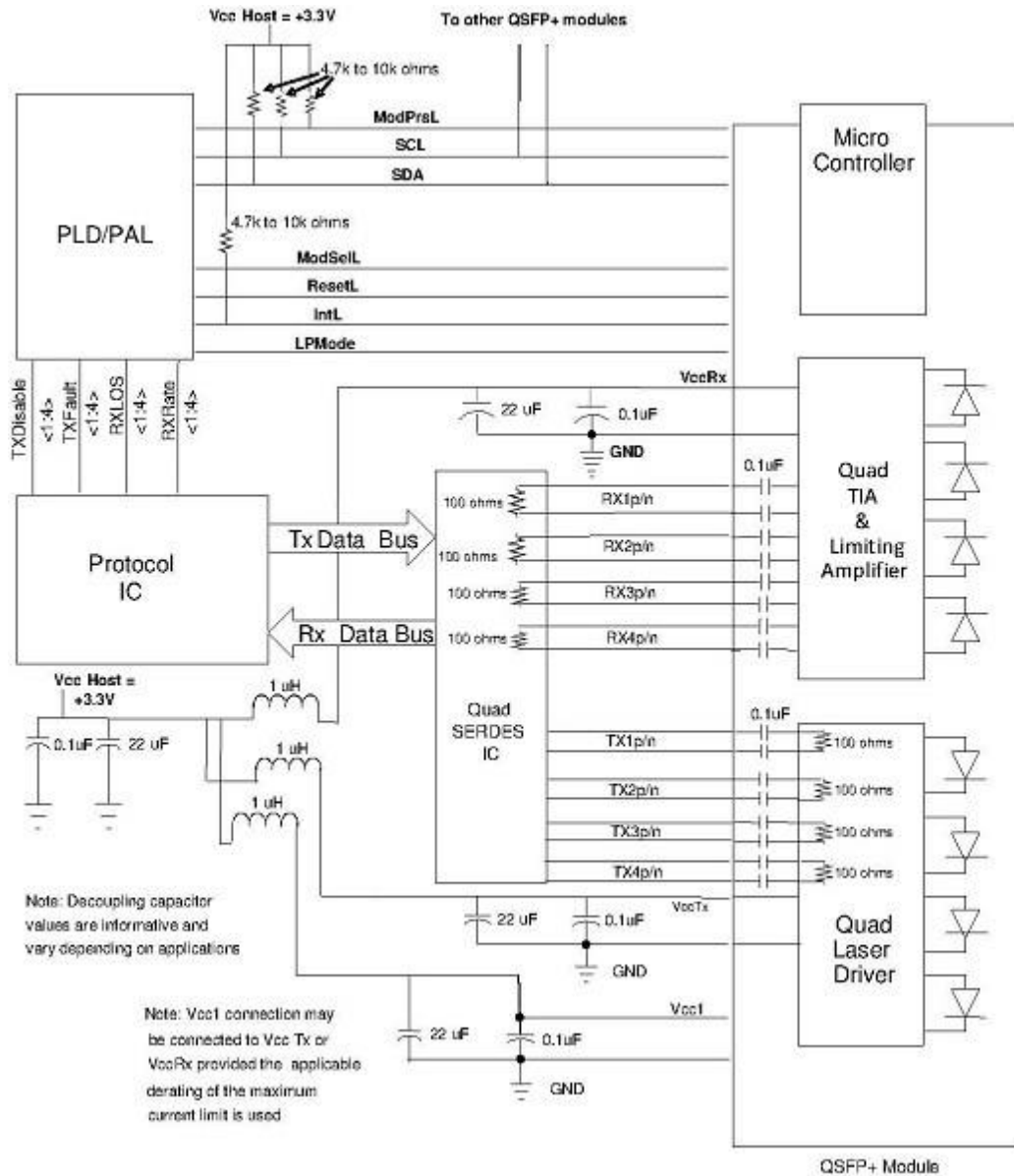

Outline Dimensions

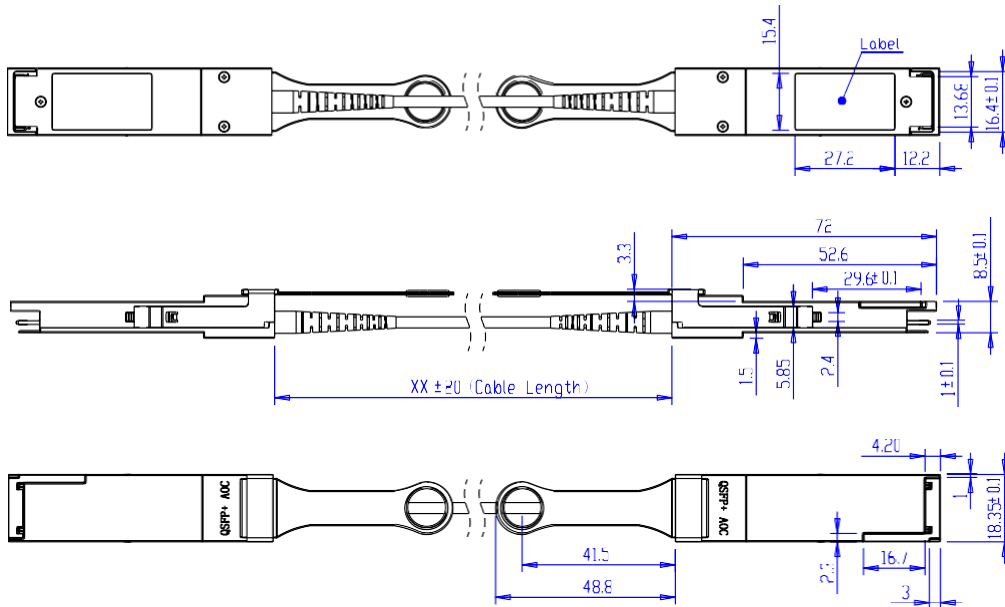

Specifications

Absolute Maximum Ratings

Parameter	Symbol	Value	Notes
Storage Temperature	Ts	-40 °C to 85 °C	
Relative Humidity	RH	5 % to 95 %	
Power Supply Voltage	Vcc	-0.3 V to 4.0 V	
Signal Input Voltage		Vcc - 0.3 V to Vcc + 0.3 V	

Recommended Operating Conditions

Parameter	Symbol	Value	Notes
Case Operating Temperature	Tcase	0 °C to 70 °C	Without air flow
Power Supply Voltage	Vcc	3.13 V to 3.46 V, 3.3 V typical	
Power Supply Current	Icc	450 mA maximum	Per cable end
Data Rate	BR	10.3125 Gbps	Each channel

General Product Characteristics

Parameter	Value	Notes
Module Form Factor	QSFP+	
Number of Lanes	4 Tx /Rx	
Maximum Aggregate Data Rate	42.0	

Maximum Data Rate per Lane	10.5	
Standard Cable Lengths	3, 5, 7, 10, 50, 100	1
Protocols Supported	Typical applications include Infiniband, Fiber Channel, 40G Ethernet	
Electrical Interface and Pin-out	38-pin edge connector	2
Standard Optical Cable Type	Multi-mode ribbon fiber cable assembly, riser-rated	
Maximum Power Consumption per End	1.5	
Management Interface	Serial, I2C-based, 400 kHz maximum frequency	3

Notes:

1. Please contact sales for other lengths
2. Pin-out as defined by the QSFP+ MSA
3. As defined by the QSFP+ MSA

Electrical Characteristics

Parameter	Symbol	Value	Notes
Supply Voltage	Vcc1, VccTx, VccRx	3.14 V to 3.46 V, 3.3 V typical	
Supply Current	Icc	450 mA maximum	
Transmitter			
Differential Data Input Swing	V _{in,pp}	180 mV to 1000 mV	1
Single Ended Input Voltage tolerance	V _{inT}	-0.3 V to 4.0 V	
Receiver			
Differential Data Output Swing	V _{out,pp}	300 mV to 850 mV	2
Single-ended Output Voltage		-0.3 V to +4.0 V	

Notes:

1. AC coupled internally. See Figure 1 for input eye mask requirements. Self-biasing 100 Ω differential input.
2. AC coupled with 100Ω differential output impedance. See Figure 2 for output eye mask.

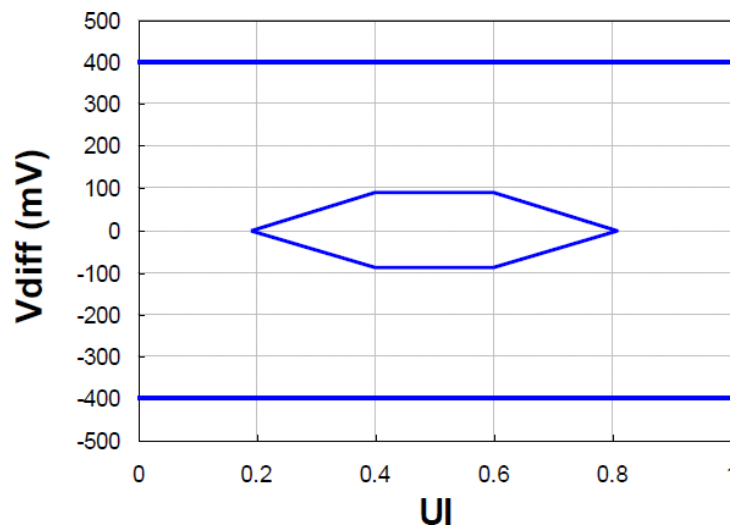

Figure 1 - Transmitter Input Differential Signal Mask

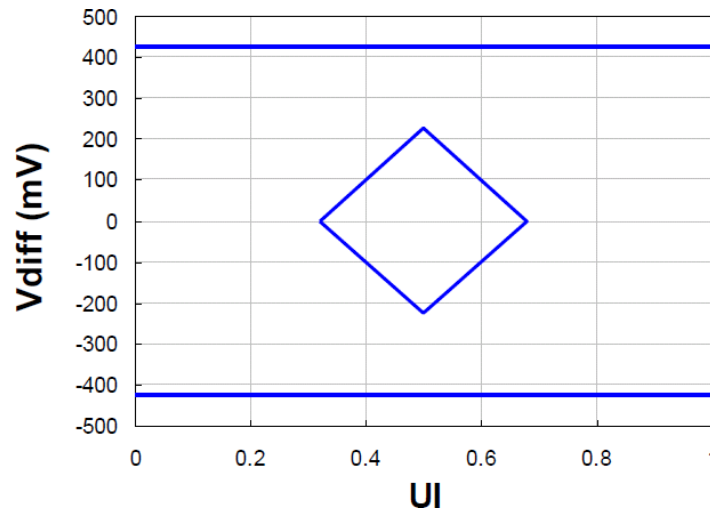

Figure 2 - Receiver Output Differential Signal Mask

High-speed Electrical Characteristics per Lane

Parameter-Inputs	Symbol	Value	Notes
Reference Differential Input Impedance	Zd	100 Ω	
Termination Mismatch	ΔZM	5% maximum	1
Input AC Common Mode Voltage		25 mV (RMS) maximum	
Differential Input Return Loss	SDD11		2, 0.01 GHz to 4.1 GHz
	SDD11		3, 4.1 GHz to 11.1 GHz
Differential to Common Mode Loss	SCD11	-10 dB maximum	0.01 GHz to 11.1 GHz
Jitter Tolerance (Total)	TJ	0.40 UI	
Jitter Tolerance (Deterministic)	DJ	0.15 UI	

Notes:

1. See SFF-8431 section D.15 Termination Mismatch for definition and test recommendations
2. Reflection coefficient given by equation $SDD11 (dB) < -12 + 2 * \sqrt{f}$, with f in GHz. See Figure 3.
3. Reflection coefficient given by equation $SDD11 (dB) < -6.3 + 13\log_{10}(f/5.5)$, with f in GHz. See Figure 3

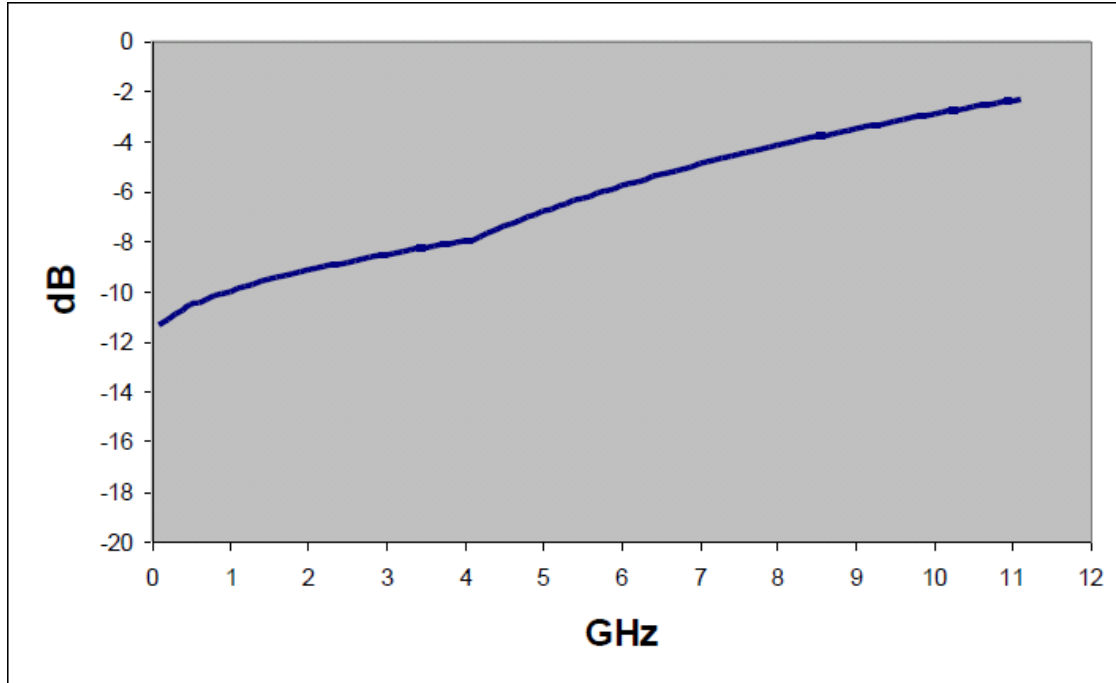

Figure 3 - Maximum Transmitter Input and Receiver Output Differential Return Loss

Parameter-Inputs	Symbol	Value	Notes
Reference Differential Output Impedance	Zd	100 Ω	
Termination Mismatch	ΔZM	5 % maximum	
Output AC Common Mode Voltage		15 mV (RMS) maximum	
Differential Output Return Loss	SDD22		4, 0.01 GHz to 4.1 GHz
	SDD22		5, 4.1 GHz to 11.1 GHz
Common Mode Output Return Loss	SCC22		6, 0.01 GHz to 2.5 GHz
	SCC22	-3 dB maximum	2.5 GHz to 11.1 GHz
Jitter Tolerance (Total)	TJ		
Output Rise and Fall time (20 % to 80 %)	tRH, tFH	24 ps minimum	
Deterministic Jitter	DJOUT	0.38 UI	7
Total Jitter	TJOUT	0.64 UI	7

Notes:

1. Reflection coefficient given by equation $SDD22 (dB) < -12 + 2 * \sqrt{f}$, with f in GHz. See Figure 3.
2. Reflection coefficient given by equation $SDD22 (dB) < -6.3 + 13\log_{10}(f/5.5)$, with f in GHz. See Figure 3.
3. Reflection coefficient given by equation $SCC22 (dB) < -7 + 1.6 * f$, with f in GHz.
4. When transmitter input jitter specs are met.

Ordering Information

Item	Description
QSFP-40-AOC-005	QSFP+ direct-attach Active OM3 MMF Optical Cable, 5-Meter Plug -in, 40Gbps
QSFP-40-AOC-010	QSFP+ direct-attach Active OM3 MMF Optical Cable, 10-Meter Plug-in, 40 Gbps
QSFP-40-AOC-020	QSFP+ direct-attach Active OM3 MMF Optical Cable, 20-Meter Plug-in, 40 Gbps
QSFP-40-AOC-030	QSFP+ direct-attach Active OM3 MMF Optical Cable, 30-Meter Plug-in, 40 Gbps
QSFP-40-AOC-050	QSFP+ direct-attach Active OM3 MMF Optical Cable, 50-Meter Plug-in, 40 Gbps
QSFP-40-AOC-070	QSFP+ direct-attach Active OM3 MMF Optical Cable, 70-Meter Plug-in, 40 Gbps
QSFP-40-AOC-075	QSFP+ direct-attach Active OM3 MMF Optical Cable, 75-Meter Plug-in, 40 Gbps

Note:

Please contact Ascent sales representative for more detailed product selection and cable lengths.

Contact Information

Ascent Communication Technology Ltd

AUSTRALIA

140 William Street, Melbourne
Victoria 3000, AUSTRALIA
Phone: +61-3-8691 2902

Hong Kong SAR

Room 1210, 12th Floor, Wing Tuck Commercial Centre
181 Wing Lok Street, Sheung Wan , Hong Kong SAR
Phone: +852-2851 4722

CHINA

Unit 1933, 600 Luban Road
200023, Shanghai, CHINA
Phone: +86-21-60232616

USA

2710 Thomes Ave
Cheyenne, WY 82001, USA
Phone: +1 203 350 9822

EUROPE

Pfarrer-Bensheimer-Strasse 7a
55129 Mainz, GERMANY
Phone: +49 (0) 6136 926 3246

VIETNAM

11th Floor, Hoa Binh Office Tower
106 Hoang Quoc Viet Street, Nghia Do Ward
Cau Giay District, Hanoi 10649, VIETNAM
Phone: +84-24-37955917

WEB: www.ascentcomtec.com

EMAIL: sales@ascentcomtec.com

Specifications and product availability are subject to change without notice.
Copyright © 2026 Ascent Communication Technology Limited. All rights reserved.
Ver. ACT_QSFP-40-AOC-XXX_Datasheet_V1c_Oct_2023