

100 Gb/s QSFP28 Active Optical Cable

QSFP28 Series

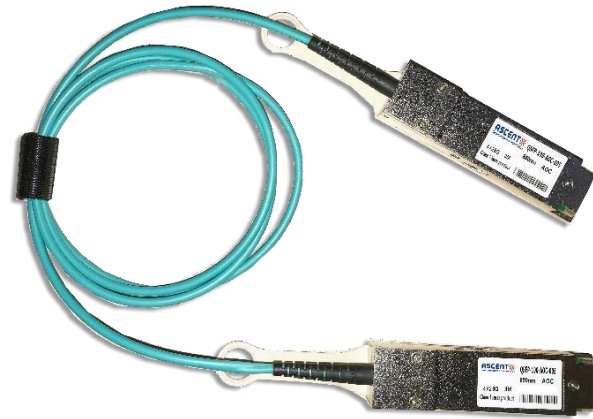

- Full duplex 4 channel 850 nm parallel active optical cable
- Up to 27.952 Gbps data rate per channel
- Up to 150 m links on OM3 multi-mode fiber
- 850 nm VCSEL technology
- Electrically hot-pluggable
- Case operating temperature range: 0 °C to +70 °C
- Power dissipation < 2.5 W per cable end
- RoHS Compliant

ASCENT 100G QSFP28 Active Optical Cable is a high-performance integrated cable suitable for high-speed core network and data center applications.

These optical cables are suitable for short-distance QSFP28 to QSFP28 data transmission and are a flexible way to connect switches within racks and across adjacent racks. Active optical cables are much thinner and lighter than copper cables, allowing for simpler installation.

The light weight and thin fiber cable also enable efficient system airflow at the headend. They are protected from environmental pollutants, and have no electromagnetic interference (EMI) issues, which can be critical in high-density racks.

Compliant with QSFP28 MSA standards, these active optical cables offer a low-cost solution for data centers and high-performance computing, and can be seamlessly integrated with different fiber types.

Key Features

- Full duplex 4 channel 850 nm parallel active optical cable
- Up to 27.952 Gbps data rate per channel
- Maximum link length of 150 m links on OM3 multi-mode fiber
- High reliability 850 nm VCSEL technology
- Electrically hot-pluggable
- Support Digital Diagnostics Monitoring (DDM)
- Case operating temperature range: 0 °C to +70 °C
- Power dissipation < 2.5 W per cable end
- Compliant to QSFP28 MSA
- RoHS Compliant

Outline Dimensions

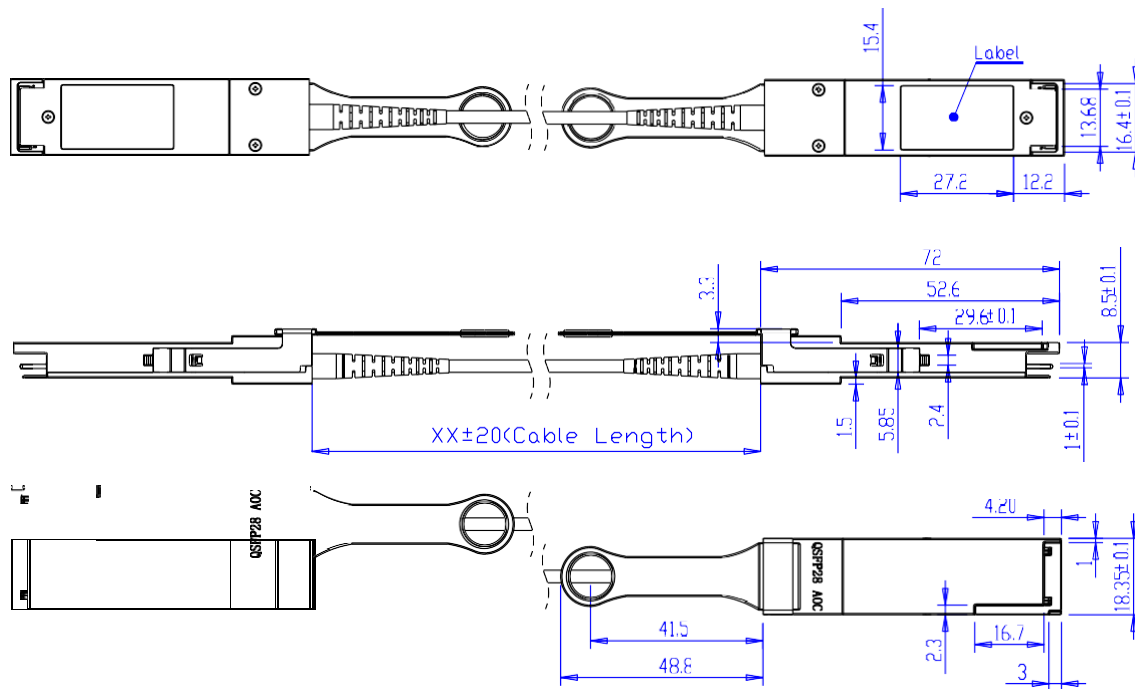

Pin Assignment

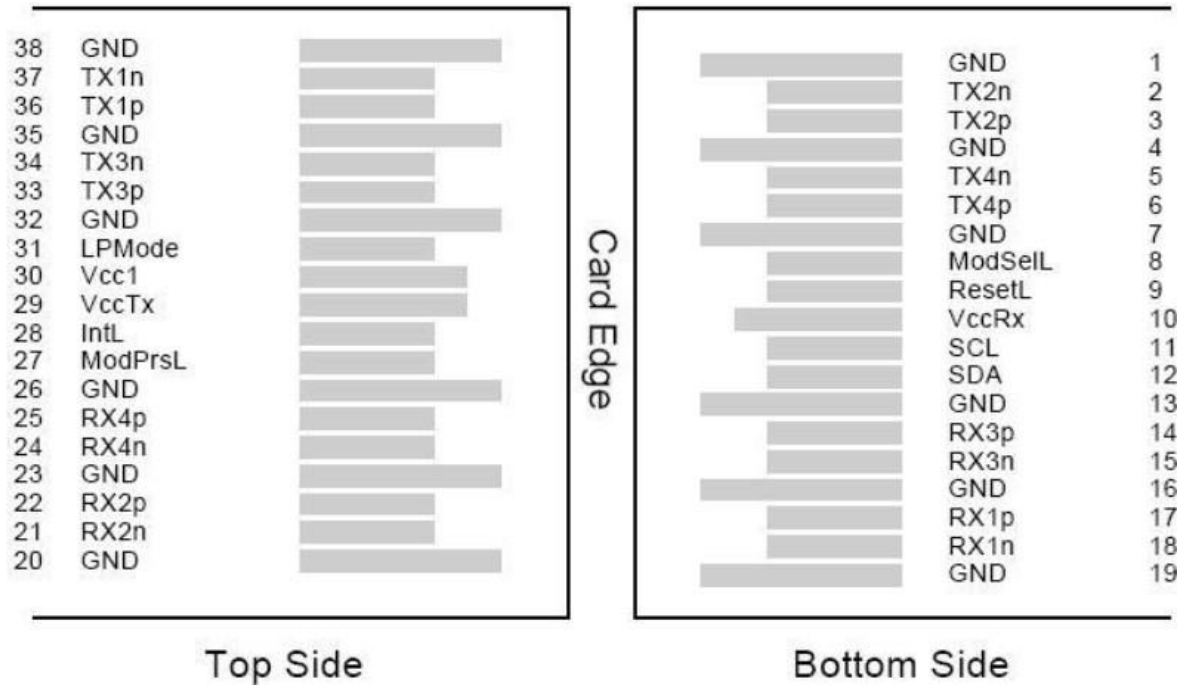

Pin out of Connector Block on Host Board

Pin	Symbol	Name/Description	Notes
1	GND	Transmitter Ground (Common with Receiver Ground)	1
2	Tx2n	Transmitter Inverted Data Input	
3	Tx2p	Transmitter Non-Inverted Data output	
4	GND	Transmitter Ground (Common with Receiver Ground)	1
5	Tx4n	Transmitter Inverted Data Input	
6	Tx4p	Transmitter Non-Inverted Data output	
7	GND	Transmitter Ground (Common with Receiver Ground)	1
8	ModSelL	Module Select	
9	ResetL	Module Reset	
10	VccRx	3.3V Power Supply Receiver	2
11	SCL	2-Wire serial Interface Clock	
12	SDA	2-Wire serial Interface Data	
13	GND	Transmitter Ground (Common with Receiver Ground)	
14	Rx3p	Receiver Non-Inverted Data Output	
15	Rx3n	Receiver Inverted Data Output	
16	GND	Transmitter Ground (Common with Receiver Ground)	1
17	Rx1p	Receiver Non-Inverted Data Output	
18	Rx1n	Receiver Inverted Data Output	
19	GND	Transmitter Ground (Common with Receiver Ground)	1
20	GND	Transmitter Ground (Common with Receiver Ground)	1
21	Rx2n	Receiver Inverted Data Output	

22	Rx2p	Receiver Non-Inverted Data Output	
23	GND	Transmitter Ground (Common with Receiver Ground)	1
24	Rx4n	Receiver Inverted Data Output	1
25	Rx4p	Receiver Non-Inverted Data Output	
26	GND	Transmitter Ground (Common with Receiver Ground)	1
27	ModPrsl	Module Present	
28	IntL	Interrupt	
29	VccTx	3.3V power supply transmitter	2
30	Vcc1	3.3V power supply	2
31	LPMODE	Low Power Mode, not connect	
32	GND	Transmitter Ground (Common with Receiver Ground)	1
33	Tx3p	Transmitter Non-Inverted Data Input	
34	Tx3n	Transmitter Inverted Data Output	
35	GND	Transmitter Ground (Common with Receiver Ground)	1
36	Tx1p	Transmitter Non-Inverted Data Input	
37	Tx1n	Transmitter Inverted Data Output	
38	GND	Transmitter Ground (Common with Receiver Ground)	1

Notes:

1. GND is the symbol for signal and supply (power) common for QSFP+ modules. All are common within the QSFP+ module and all module voltages are referenced to this potential unless otherwise noted. Connect these directly to the host board signal common ground plane.
2. VccRx, Vcc1 and VccTx are the receiving and transmission power suppliers and shall be applied concurrently. Recommended host board power supply filtering is shown below. Vcc Rx, Vcc1 and Vcc Tx may be internally connected within the QSFP28 transceiver module in any combination. The connector pins are each rated for a maximum current of 500mA.

Host – Transceiver Interface Block Diagram

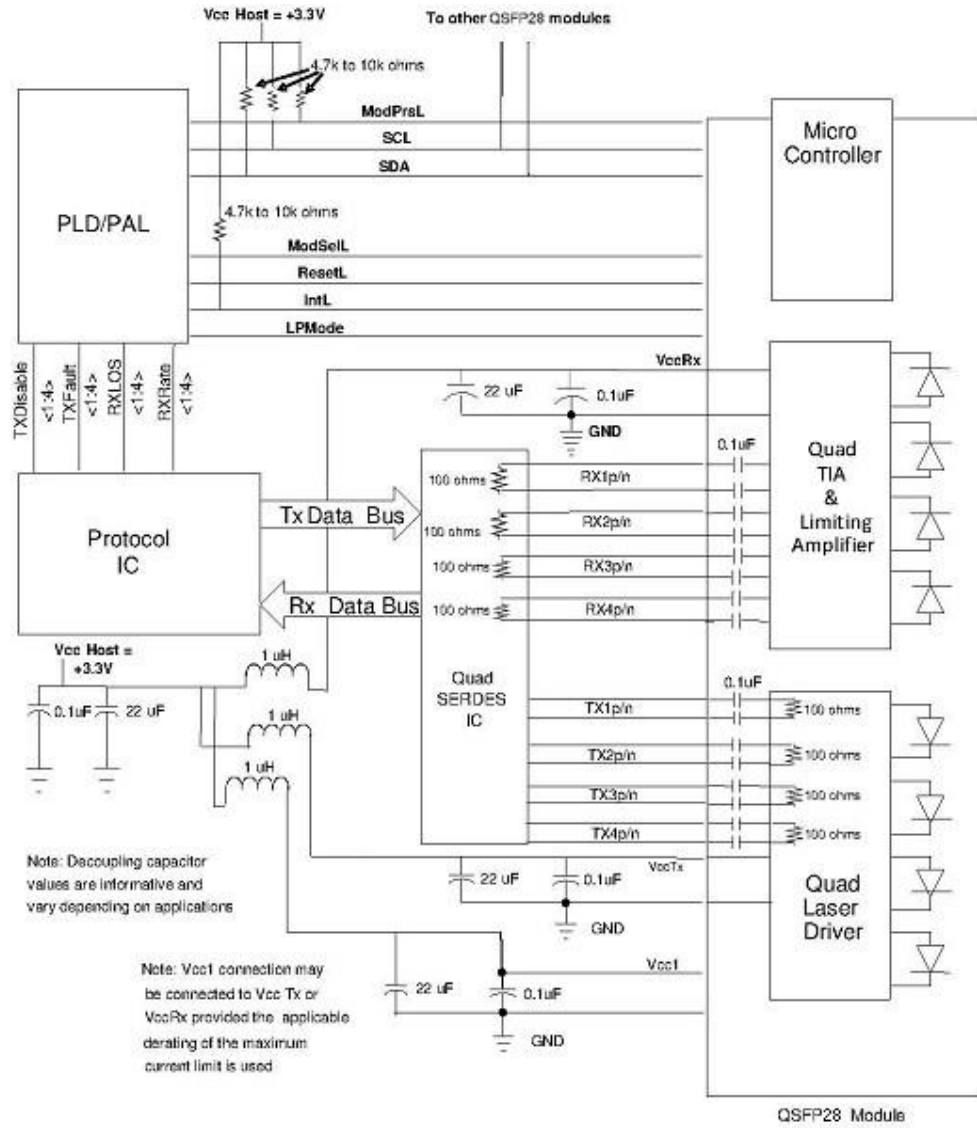

Specifications

Absolute Maximum Ratings

Parameter	Symbol	Min.	Typ.	Max.	Unit	Notes
Storage Temperature	Ts	-40	-	85	°C	
Relative Humidity	RH	5	-	95	%	
Power Supply Voltage	VCC	-0.3	-	4	V	
Signal Input Voltage		Vcc-0.3	-	Vcc+0.3	V	

Recommended Operating Conditions

Parameter	Symbol	Min.	Typ.	Max.	Unit	Notes
Case Operating Temperature	Tcase	0	-	70	°C	Without air flow
Power Supply Voltage	VCC	3.14	3.3	3.46	V	
Power Supply Current	ICC	-		750	mA	Per cable end
Data Rate	BR		25.78125		Gbps	Each channel

General Product Characteristics

Parameter	Description	Notes
Module Form Factor	QSFP28	
Number of Lanes	4 Tx /Rx	
Maximum Aggregate Data Rate	111.8 Gb/s	
Maximum Data Rate per Lane	27.952 Gb/s	
Standard Cable Lengths	3 m, 5 m, 7 m, 10 m	Other lengths, please contact sales
Protocols Supported	Typical applications include Infiniband, Fiber Channel, 100G Ethernet	
Electrical Interface and Pin-out	38-pin edge connector	Pin-out as defined by the QSFP28 MSA
Standard Optical Cable Type	Multimode ribbon fiber cable assembly, riser-rated	
Maximum Power Consumption	2.5 W per end	
Management Interface	Serial, I2C-based, 400 kHz maximum frequency	As defined by the QSFP28 MSA

Note: 100G Ethernet & 100GBASE-SR4 and ITU-T OTU4 has different register settings, not auto-negotiation

High-speed Electrical Characteristics per Lane

Parameter-Inputs	Symbol	Min.	Typ.	Max.	Unit	Notes
Input Electrical sSecifications (per Lane)						
Differential Voltage pk-pk				900	mV	
Common Mode Noise RMS				17.5	mV	
Differential Termination Resistance Mismatch				10	%	
Differential Return Loss	SDD22					
Common Mode to Differential Conversion and Differential to Common Mode Conversion	SDC22, SCD22		Per OIF CEI-28G-VSR and CAUI-4 requirements		dB	
Common Mode Return Loss	SCC22				dB	
Transition Time, 20 to 80 %	Tr, Tf	10			ps	

Common Mode Voltage	Vcm	-0.3	2.8	V
Eye Width at 1E-15 probability	EW15	0.46		UI
Eye Height at 1E-15 probability	EH15	94		mV
Output Electrical Specifications (per Lane)				
Differential Voltage pk-pk			900	mV
Common Mode Voltage	Vcm	-350	2850	mV
Common Mode Noise RMS			17.5	mV
Differential Termination Resistance Mismatch			10	%
Differential Return Loss	SDD22			dB
Common Mode to Differential Conversion and Differential to Common Mode Conversion	SDC22, SCD22	Per OIF CEI-28G-VSR and CAUI-4 requirements		dB
Common Mode Return Loss	SCC22			dB
Output Rise and Fall time (20 % to 80 %)	tRH, tFH	9.5		ps
Vertical Eye Closure	VEC		5.5	dB
Eye Width at 1E-15 probability	EW15	0.57		UI

Ordering Information

Product Name	Product Description
QSFP-100-AOC-001	100G QSFP28 to QSFP28 Active Optical Cable 1M
QSFP-100-AOC-003	100G QSFP28 to QSFP28 Active Optical Cable 3M
QSFP-100-AOC-005	100G QSFP28 to QSFP28 Active Optical Cable 5M
QSFP-100-AOC-010	100G QSFP28 to QSFP28 Active Optical Cable 10M
QSFP-100-AOC-015	100G QSFP28 to QSFP28 Active Optical Cable 15M

Contact Information

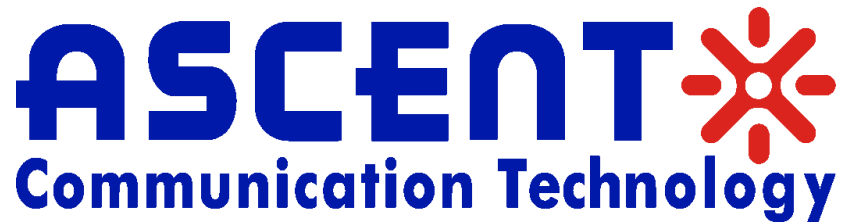

Ascent Communication Technology Ltd

AUSTRALIA

140 William Street, Melbourne
Victoria 3000, AUSTRALIA
Phone: +61-3-8691 2902

CHINA

Unit 1933, 600 Luban Road
200023, Shanghai, CHINA
Phone: +86-21-60232616

EUROPE

Pfarrer-Bensheimer-Strasse 7a
55129 Mainz, GERMANY
Phone: +49 (0) 6136 926 3246

WEB: www.ascentcomtec.com

Hong Kong SAR

Unit 9, 12th Floor, Wing Tuck Commercial Centre
177 Wing Lok Street, Sheung Wan, Hong Kong SAR
Phone: +852-2851 4722

USA

2710 Thomes Ave
Cheyenne, WY 82001, USA
Phone: + 1 203 350 9822

VIETNAM

11th Floor, Hoa Binh Office Tower
106 Hoang Quoc Viet Street, Nghia Do Ward
Cau Giay District, Hanoi 10649, VIETNAM
Phone: +84-24-37955917

EMAIL: sales@ascentcomtec.com

Specifications and product availability are subject to change without notice.
Copyright © 2024 Ascent Communication Technology Limited. All rights reserved.
Ver. ACT_QSFP-100-AOC-000_Datasheet_V1c_Oct_2018